

SSC-JE

STAFF SELECTION COMMISSION – JUNIOR ENGINEER

MAINS EXAM

CIVIL ENGINEERING

SUBJECTWISE CONVENTIONAL
SOLVED PAPERS

(2004-2017)



Office: F-126, (Lower Basement), Katwaria Sarai, New Delhi-110 016

Phone: 011-2652 2064 ■ **Mobile:** 81309 09220, 97118 53908

Email: info.publications@iesmaster.org, info@iesmaster.org

Web: iesmasterpublications.com, iesmaster.org



IES MASTER PUBLICATION

F-126, (Lower Basement), Katwaria Sarai, New Delhi-110016

Phone : 011-26522064, **Mobile** : 8130909220, 9711853908

E-mail : info.publications@iesmaster.org

Web : iesmasterpublications.com

All rights reserved.

Copyright © 2019, by IES MASTER Publication No part of this booklet may be reproduced, or distributed in any form or by any means, electronic, mechanical, photocopying, recording, or otherwise or stored in a database or retrieval system without the prior permission of IES MASTER Publication, New Delhi. Violates are liable to be legally prosecuted.

First Edition : 2019

Typeset at : IES Master Publication, New Delhi-110016

PREFACE

Thus far, no further... it is one book that covers all the papers, all the questions asked in the SSC-JE Mains exams. If previous years questions give an insight into the mind of examiner, its solutions give you the direction and the distance you need to travel with regard to each and every subject, topic, concept, and numerical. It goes even further in terms of answer writing – giving you language, diagrams, and detail in which you need to answer the questions with regard to the marks allocated to each question.

All this boils down to save time and energy which in turn relieves you of the pressure, more importantly in the exam hall. The book “**IES Master SSC-JE Subject-wise Conventional Solved Papers**” covers questions from the past 13 years. Being subjectwise conventional solutions, it gives you complete line and length on which questions have been asked, or in other words the importance that has been associated with one particular subject, topic or concept.

The best way to make optimum use of this book is to go through the questions, attempt solutions, and then cross-check your solutions with the solutions provided in the book. In fact, this act of self-assessment, if you can do in honesty to yourself, can put you on an auto-pilot mode. This indeed, if achieved, can help you achieve things far beyond than the stated objective.

IES Master Research & Development team has taken all care in bringing out this book. Scientifically proven methods have been incorporated in putting up the model answers. So if you can write a theory answer in bullet points, or can put a figure in explaining a concept, or in deriving a numerical, you not only minimize chances of writing wrong spellings, or going vague, or committing careless mistakes but also impress the examiner while making your answers eye catching.

So, go ahead and make the most out of this one among the masterpieces from IES Master. Suggestions from students, teachers & educators are always welcome.

IES MASTER PUBLICATION
NEW DELHI

EXAM PATTERN

PAPERS	MODE OF EXAMINATION	SUBJECT	NUMBER OF QUESTIONS	MAXIMUM MARKS	DURATION & TIMINGS
Paper-I Objective Type	Computer Base Mode	(i) General Intelligence Reasoning	50	50	2 Hours
		(ii) General Awareness	50	50	Morning Shift
		(iii) General Engineering (Civil and Structural)	100	100	Evening Shift
Paper-II Conventional Type	Written Examination	General Engineering (Civil and Structural)		300	2 Hours

SYLLABUS

PAPER-I

General Intelligence & Reasoning

The Syllabus for General Intelligence would include questions of both verbal and non-verbal type. The test may include questions on analogies, similarities, differences, space visualization, problem solving, analysis, judgement, decision making, visual memory, discrimination, observation, relationship concepts, arithmetical reasoning, verbal and figure classification, arithmetical number series etc. The test will also include questions designed to test the candidate's abilities to deal with abstract ideas and symbols and their relationships, arithmetical computations and other analytical functions.

General Awareness

Questions will be aimed at testing the candidate's general awareness of the environment around him/her and its application to society. Questions will also be designed to test knowledge of current events and of such matters of everyday observations and experience in their scientific aspect as may be expected of any educated person. The test will also include questions relating to India and its neighbouring countries especially pertaining to History, Culture, Geography, Economic Scene, General Polity and Scientific Research, etc. These questions will be such that they do not require a special study of any discipline.

General Engineering

Civil and Structural

Theory of Structures, RCC Design, Steel Design, Building Materials and Concrete Technology, Estimating, Costing and Valuation, Environmental Engineering, Soil Mechanics, Hydraulics, Irrigation Engineering, Transportation Engineering and Surveying.

PAPER-II

Structural Engineering : Theory of structures: Elasticity constants, types of beams – determinate and indeterminate, bending moment and shear force diagrams of simply supported, cantilever and over hanging beams. Moment of area and moment of inertia for rectangular & circular sections, bending moment and shear stress for tee, channel and compound sections, chimneys, dams and retaining walls, eccentric loads, slope deflection of simply supported and cantilever beams, critical load and columns, Torsion of circular section.

RCC Design : RCC beams-flexural strength, shear strength, bond strength, design of singly reinforced and double reinforced beams, cantilever beams. T-beams, lintels. One way and two way slabs, isolated footings. Reinforced brick works, columns, staircases, retaining wall, water tanks (RCC design questions may be based on both Limit State and Working Stress methods).

Steel Design : Steel design and construction of steel columns, beams roof trusses plate girders.

Building Materials : Physical and Chemical properties, classification, standard tests, uses and manufacture / quarrying of materials e.g. building stones, silicate based materials, cement (Portland), asbestos products, timber and wood based products, laminates, bituminous materials, paints, varnishes.

Concrete Technology : Properties, Advantages and uses of concrete, cement aggregates, importance of water quality, water cement ratio, workability, mix design, storage, batching, mixing, placement, compaction, finishing and curing of concrete, quality control of concrete, hot weather and cold weather concreting, repair and maintenance of concrete structures.

Estimating, Costing and Valuation : Estimate, glossary of technical terms, analysis of rates, methods and unit of measurement, items of work – earthwork, Brick work (Modular & Traditional bricks), RCC work, Shuttering, Timber work, Painting, Flooring, Plastering, Boundary wall, Brick building, Water Tank, Septic Tank, Bar bending schedule, Centre line method, Mid-section formula, Trapezoidal formula, Simpson's rule. Cost estimate of Septic tank, flexible pavements, Tube well, isolates and combined footings, Steel Truss, Piles and pilecaps. Valuation – Value and cost, scrap value, salvage value, assessed value, sinking fund, depreciation and obsolescence, methods of valuation.

Environmental Engineering : Quality of water, source of water supply, purification of water, distribution of water, need of sanitation, sewerage systems, circular sewer, oval sewer, sewer appurtenances, sewage treatments. Surface water drainage. Solid waste management – types, effects, engineered management system. Air pollution – pollutants, causes, effects, control. Noise pollution – cause, health effects, control.

Soil Mechanics : Origin of soil, phase diagram, Definitions-void ratio, porosity, degree of saturation, water content, specific gravity of soil grains, unit weights, density index and interrelationship of different parameters. Grain size distribution curves and their uses. Index properties of soils, Atterberg's limits, IS soil classification and plasticity chart. Permeability of soil, coefficient of permeability, determination of coefficient of permeability, Unconfined and confined aquifers, effective stress, quick sand, consolidation of soils, Principles of consolidation, degree of consolidation, pre-consolidation pressure, normally consolidated soil, e-log p curve, computation of ultimate settlement. Shear strength of soils, direct shear test, Vane shear test, Triaxial test. Soil compaction, Laboratory compaction test, Maximum dry density and optimum moisture content, earth pressure theories, active and passive earth pressures, Bearing capacity of soils, plate load test, standard penetration test.

Hydraulics : Fluid properties, hydrostatics, measurements of flow, Bernoulli's theorem and its application, flow through pipes, flow in open channels, weirs, flumes, spillways, pumps and turbines.

Irrigation Engineering : Definition, necessity, benefits, ill effects of irrigation, types and methods of irrigation, Hydrology – Measurement of rainfall, run off coefficient, rain gauge, losses from precipitation – evaporation, infiltration, etc. Water requirement of crops, duty, delta and base period, Kharif and Rabi Crops, Command area, Time factor, Crop ratio, Overlap allowance, Irrigation efficiencies. Different type of canals, types of canal irrigation, loss of water in canals. Canal lining – types and advantages. Shallow and deep to wells, yield from a well. Weir and barrage, Failure of weirs and permeable foundation, Slit and Scour, Kennedy's theory of critical velocity. Lacey's theory of uniform flow. Definition of flood, causes and effects, methods of flood control, water logging, preventive measure. Land reclamation, Characteristics of affecting fertility of soils, purposes, methods, description of land and reclamation processes. Major irrigation projects in India.

Transportation Engineering : Highway Engineering – cross sectional elements, geometric design, types of pavements, pavement materials – aggregates and bitumen, different tests, Design of flexible and rigid pavements – Water Bound Macadam (WBM) and Wet Mix Macadam (WMM), Gravel Road, Bituminous construction, Rigid pavement joint, pavement maintenance, Highway drainage.

Railway Engineering : Components of permanent way – sleepers, ballast, fixtures and fastening, track geometry, points and crossings, track junction, stations and yards. Traffic Engineering – Different traffic survey, speed-flow-density and their inter-relationships, intersections and interchanges, traffic signals, traffic operation, traffic signs and markings, road safety.

Surveying : Principles of surveying, measurement of distance, chain surveying, working of prismatic compass, compass traversing, bearings, local attraction, plane table surveying, theodolite traversing, adjustment of theodolite, Levelling. Definition of terms used in levelling, contouring, curvature and refraction corrections, temporary and permanent adjustments of dumpy level, methods of contouring, uses of contour map, tachometric survey, curve setting, earth work calculation, advanced surveying equipment.

CONTENT

1. THEORY OF STRUCTURES	01 – 83
PART-A: STRENGTH OF MATERIALS	02 – 59
PART-B: STRUCTURAL ANALYSIS	60 – 83
2. RCC DESIGN	84 – 150
3. STEEL DESIGN	151 – 188
4. BUILDING MATERIALS AND CONCRETE TECHNOLOGY	189 – 252
5. ESTIMATING, COSTING AND VALUATION	253 – 256
6. ENVIRONMENTAL ENGINEERING	257 – 282
7. SOIL MECHANICS	283 – 336
8. HYDRAULICS	337 – 374
9. IRRIGATION ENGINEERING	375 – 392
10. TRANSPORTATION ENGINEERING	393 – 406
11. SURVEYING	407 – 442



UNIT-1

THEORY OF STRUCTURE

SYLLABUS

Structural Engineering: Theory of structures: Elasticity constants, types of beams—determinate and indeterminate, bending moment and shear force diagrams of simply supported, cantilever and over hanging beams. Moment of area and moment of inertia for rectangular & circular sections, bending moment and shear stress for tee, channel and compound sections, chimneys, dams and retaining walls, eccentric loads, slope deflection of simply supported and cantilever beams, critical load and columns, Torsion of circular section.

1

PART-A

STRENGTH OF MATERIALS

Q-1: The tensile test has been performed on a 50 mm long steel tube having 18 mm external diameter and 12 mm internal diameter. The axial load of 2 kN produced a stretch of 3.36×10^{-3} mm and a lateral contraction of the outer diameter of 3.62×10^{-4} mm. calculate young's modulus, Poisson's ratio, and bulk modulus for the material.

[3×5 = 15 Marks, SSC JE-2004]

Sol:

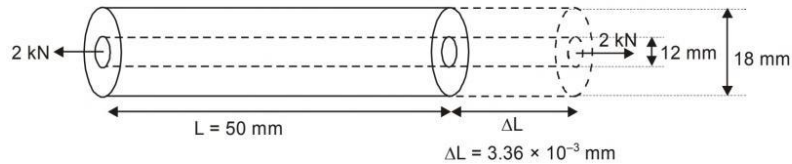

Data given:

Gauge length, $L = 50 \text{ mm}$
 Extension in length, $\Delta L = 3.36 \times 10^{-3} \text{ mm}$
 External diameter, $D_o = 18 \text{ mm}$
 Internal diameter, $D_i = 12 \text{ mm}$
 Axial load, $P = 2 \text{ kN}$

Lateral contraction of outer diameter = $\Delta D_o = 3.62 \times 10^{-4} \text{ mm}$

Calculation for Young's modulus (E):

We know that,

$$\Delta L = \frac{PL}{AE}$$

∴

$$E = \frac{PL}{A \times \Delta L}$$

$$E = \frac{2 \times 10^3 \times 50}{\left(\frac{\pi}{4} \times (18^2 - 12^2)\right) \times 3.36 \times 10^{-3}}$$

$$E = 210.522 \times 10^3 \text{ N/mm}^2 = 2.1052 \times 10^5 \text{ N/mm}^2$$

Calculation for Poisson's ratio (μ):

$$\epsilon_y = \frac{3.62 \times 10^{-4}}{18} = -2.011 \times 10^{-5}$$

$$\epsilon_x = \frac{3.36 \times 10^{-3}}{50} = 6.72 \times 10^{-5}$$

$$\mu = -\left(\frac{\epsilon_y}{\epsilon_x}\right) = \frac{\text{Lateral strain}}{\text{Axial strain}}$$

$$\mu = -\frac{(-2.011 \times 10^{-5})}{6.72 \times 10^{-5}} = 0.299 = 0.3$$

Calculation for Bulk modulus (K):

$$E = 3K(1 - 2\mu)$$

$$K = \frac{E}{3(1 - 2\mu)}$$

$$K = \frac{210.522 \times 10^3}{3(1 - 2 \times 0.3)}$$

$$K = 175.435 \times 10^3 \text{ N/mm}^2$$

$$= 1.754 \times 10^5 \text{ N/mm}^2$$

Q-2: A horizontal beam ABC of total length 5 m is simply supported over the span AB (length, 4 m) and overhang BC (length, 1 m) as shown in figure. The beam carries a concentrated load of 50 kN at mid point of span AB and a uniformly distributed load of 40 kN per meter over the overhang portion BC. Draw the bending moment and shear force diagram indicating values at significant points.

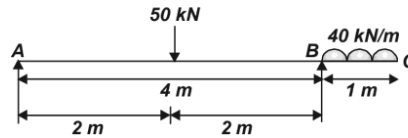

[15 Marks, SSC JE-2004]

Sol:

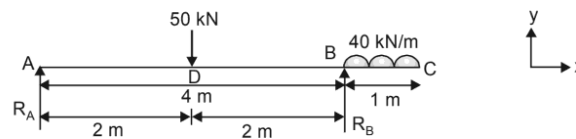
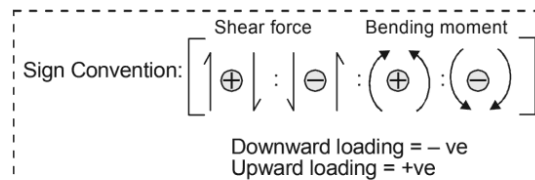

Reaction Calculation:

From $\Sigma F_y = 0;$

$$R_A + R_B = 50 + 40 \times 1 = 90 \text{ kN}$$

From $\Sigma M_A = 0; \curvearrowright$

$$50 \times 2 - R_B \times 4 + 40 \times 4.5 = 0$$

$$R_B = 70 \text{ kN } \uparrow$$

$$R_A = 20 \text{ kN } \uparrow$$

For span AD [$0 \leq x < 2$ m]

$$V = R_A = 20 \text{ kN}$$

$$M = R_A x = 20x \quad (\text{linear})$$

$$\text{at } x = 0, V = 20 \text{ kN, at } x = 2, V = 20 \text{ kN}$$

$$\text{at } x = 0, M = 0, \text{ at } x = 2, M = 40 \text{ kNm}$$

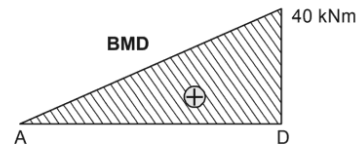
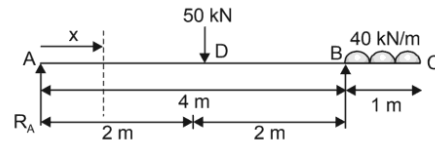
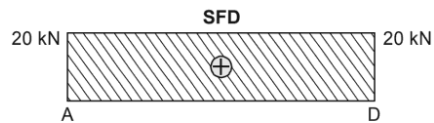

For span DB [$2 \text{ m} \leq x < 4$ m]

$$V = 20 - 50 = -30 \text{ kN}$$

$$M = 20x - 50(x - 2) = 100 - 30x$$

$$\text{at } x = 2, V = -30 \text{ kN; at } x = 4, V = -30 \text{ kN}$$

$$\text{at } x = 2, M = 40 \text{ kNm, at } x = 4, M = -20 \text{ kNm}$$

Point at which $M = 0$

$$100 - 30x = 0$$

$$x = \frac{100}{30} = 3.33 \text{ m from A.}$$

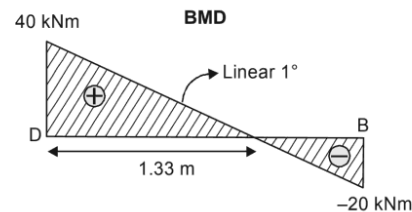
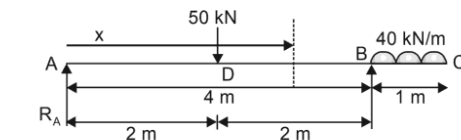
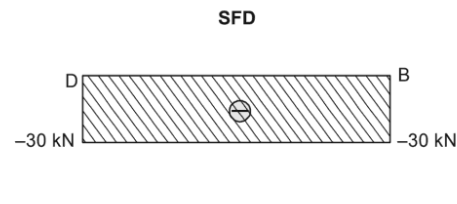

For span BC [$4 \text{ m} \leq x < 5$ m]

$$V = -30 + 70 - 40(x - 4) = 40 - 40(x - 4)$$

$$M = 20x - 50(x - 2) + 70(x - 4) - 40 \times \frac{(x - 4)^2}{2}$$

$$\text{at } x = 4, V = 40 \text{ kN, at } x = 5, V = 0$$

$$\text{at } x = 4, M = -20 \text{ kNm, at } x = 5, M = 0$$

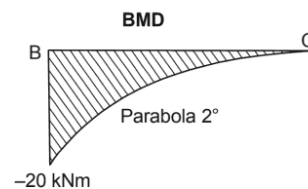
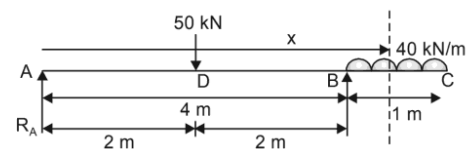
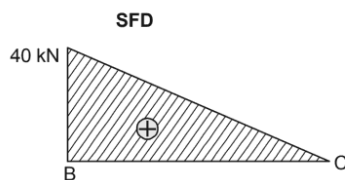

SFD and BMD

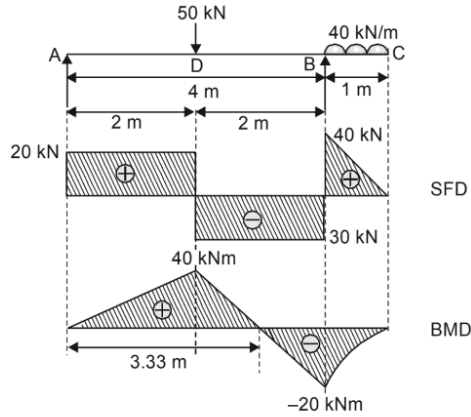

Q-3: Find the moment of inertia of the section in figure below about x-x axis.

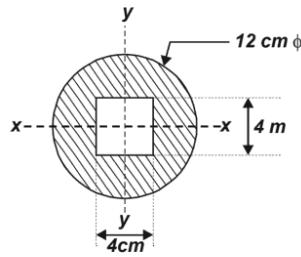

[10 Marks, SSC JE-2004]

Sol:

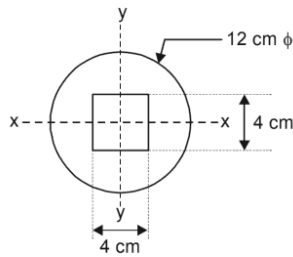

(i) Moment of inertia of solid circular section about x-x axis

$$I_{xx(\text{circle})} = \frac{\pi}{64} \times d^4$$

$$= \frac{\pi}{64} \times 12^4 = 1017.88 \text{ cm}^4$$

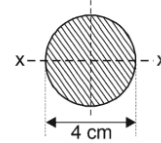

(ii) Moment of inertia of square cut out about x-x axis

$$I_{xx(\text{square})} = \frac{bd^3}{12} = \frac{4 \times 4^3}{12}$$

$$= 21.33 \text{ cm}^4$$

