



# NARUTO

**SHONEN JUMP MANGA**

Story & Art by

**Masashi Kishimoto** volume

**10**



岸本 齊史

The *Naruto* comics are already at volume 10! In the blink of an eye, we've reached double digits! Although I doubt that triple digits is a milestone we'll ever achieve, it would make me exceedingly happy if all of you would continue to read and enjoy *Naruto*, without ever getting bored, for the entire run of the series!

—Masashi Kishimoto, 2001

Author/artist Masashi Kishimoto was born in 1974 in rural Okayama Prefecture, Japan. After spending time in art college, he won the Hop Step Award for new manga artists with his manga **Karakuri** (Mechanism). Kishimoto decided to base his next story on traditional Japanese culture. His first version of **Naruto**, drawn in 1997, was a one-shot story about fox spirits; his final version, which debuted in **Weekly Shonen Jump** in 1999, quickly became the most popular ninja manga in Japan.





**NARUTO VOL. 10**  
**SHONEN JUMP Manga Edition**

This manga contains material that was originally published in English in **SHONEN JUMP** #39–41. Artwork in the magazine may have been slightly altered from that presented here.

STORY AND ART BY MASASHI KISHIMOTO

English Adaptation/Jo Duffy, Frances E. Wall  
Translation/Mari Morimoto  
Touch-up Art & Lettering/Heidi Szykowny  
Additional Touch-up/Josh Simpson  
Design/Sean Lee  
Series Editor/Joel Enos  
Editor/Frances E. Wall

NARUTO © 1999 by Masashi Kishimoto. All rights reserved. First published in Japan in 1999 by SHUEISHA Inc., Tokyo. English translation rights arranged by SHUEISHA Inc.

The rights of the author(s) of the work(s) in this publication to be so identified have been asserted in accordance with the Copyright, Designs and Patents Act 1988. A CIP catalogue record for this book is available from the British Library.

Some artwork has been modified from the original Japanese edition.

The stories, characters and incidents mentioned in this publication are entirely fictional.

No portion of this book may be reproduced or transmitted in any form or by any means without written permission from the copyright holders.

Printed in the U.S.A.

Published by VIZ Media, LLC  
P.O. Box 77010  
San Francisco, CA 94107

1098

First printing, June 2006  
Eighth printing, December 2011



[www.viz.com](http://www.viz.com)

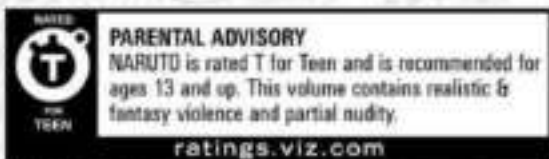



SHONEN JUMP MANGA



VOL. 10

A SPLENDID NINJA

STORY AND ART BY

MASASHI KISHIMOTO



### SAKURA サクラ

Smart and studious, Sakura is the brightest of Naruto's classmates, but she's constantly distracted by her crush on Sasuke. Her goal: to win Sasuke's heart!

### NARUTO ナルト

When Naruto was born, a destructive fox spirit was imprisoned inside his body. Spurned by the older villagers, he's grown into an attention-seeking troublemaker. His goal: to become the village's next Hokage.

### SASUKE サスケ

The top student in Naruto's class, Sasuke comes from the prestigious Uchiha clan. His goal: to get revenge on a mysterious person who wronged him in the past.





**Gaara** 我愛羅

Bloodthirsty Gaara is one of the scariest ninja competing in the Chūnin Exams.



**Rock Lee** ロック・リー

Lee has been carefully observing the other students' fights while his anticipation for his own battle builds. Now it's about to begin!



**Might Guy** マイト・ガイ

The flamboyant Master Guy is Lee's idol...and Kakashi's rival!



**Kakashi** カカシ

Although he doesn't have an especially warm personality, Kakashi is protective of his students.



**Orochimaru** 大蛇丸

This nefarious master of disguise placed a mysterious curse-mark on Sasuke and hopes to mold Sasuke into his successor.



**Kabuto** カブト

A spy for Orochimaru's village of Otogakure (The Village Hidden in the Sound), Kabuto has been living a double life in Konohagakure since childhood.

## THE STORY SO FAR...

Twelve years ago, a destructive nine-tailed fox spirit attacked the ninja village of Konohagakure. The Hokage, or village champion, defeated the fox by sealing its soul into the body of a baby boy. Now that boy, Uzumaki Naruto, has grown up to become a ninja-in-training, learning the art of ninjutsu with his classmates Sakura and Sasuke.

Naruto, Sasuke and Sakura (along with six other teams of student ninja) have moved on to the third portion of the Chūnin (Journeyman Ninja) Selection Exam—a series of no-holds-barred, one-on-one bouts that begin with a set of preliminary matches. As the preliminaries continue, the battles become increasingly vicious and it's clear that lives are on the line. After the fight between Hyuga Hinata and her cousin Hyuga Neji ends with Hinata being rushed to the emergency room, tensions are at an all-time high. Then the next two combatants are announced: Rock Lee and Gaara!



# NARUTO

VOL. 10

A SPLENDID NINJA

## CONTENTS



NUMBER 82:	LEE'S SECRET!!	7
NUMBER 83:	THE ULTIMATE DEFENSE...CRUMBLES?!	27
NUMBER 84:	THE GENIUS OF HARD WORK...!!	45
NUMBER 85:	NOW, OF ALL TIMES...!!	65
NUMBER 86:	A SPLENDID NINJA...!!	83
NUMBER 87:	THE PRELIMINARIES...COMPLETED!!	101
NUMBER 88:	WHAT ABOUT SASUKE...?!	119
NUMBER 89:	NARUTO'S WISH...!!	139
NUMBER 90:	WHAT ABOUT MY TRAINING?!	158
PREVIEWS		176



# Number 82: Lee's Secret!!





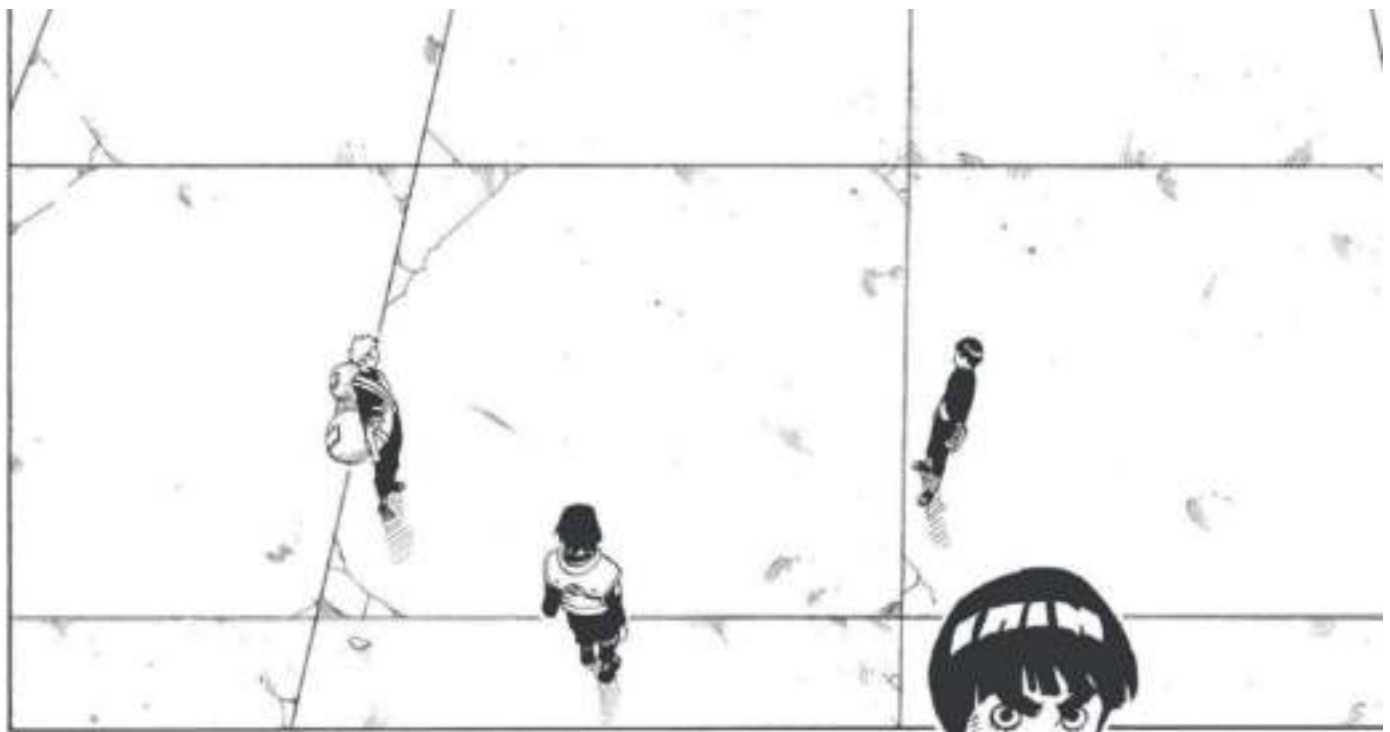





HEH... HE'S  
NO MATCH  
FOR  
GAARA.

HE MAY BE FAST...  
...BUT HIS KICK  
WASN'T ANY-  
THING SPECIAL.



Hop



KONOHA HURRICANE!!!



FWNSH

THOP

...SAND ?!  
...!

!!

...

















THE CHARACTERS BELOW SAY "KONJŌ," MEANING "GUTS," "TRUE GRIT" OR "WILLPOWER."





















 Number 83: The Ultimate Defense...

Crumbles?!  
zz

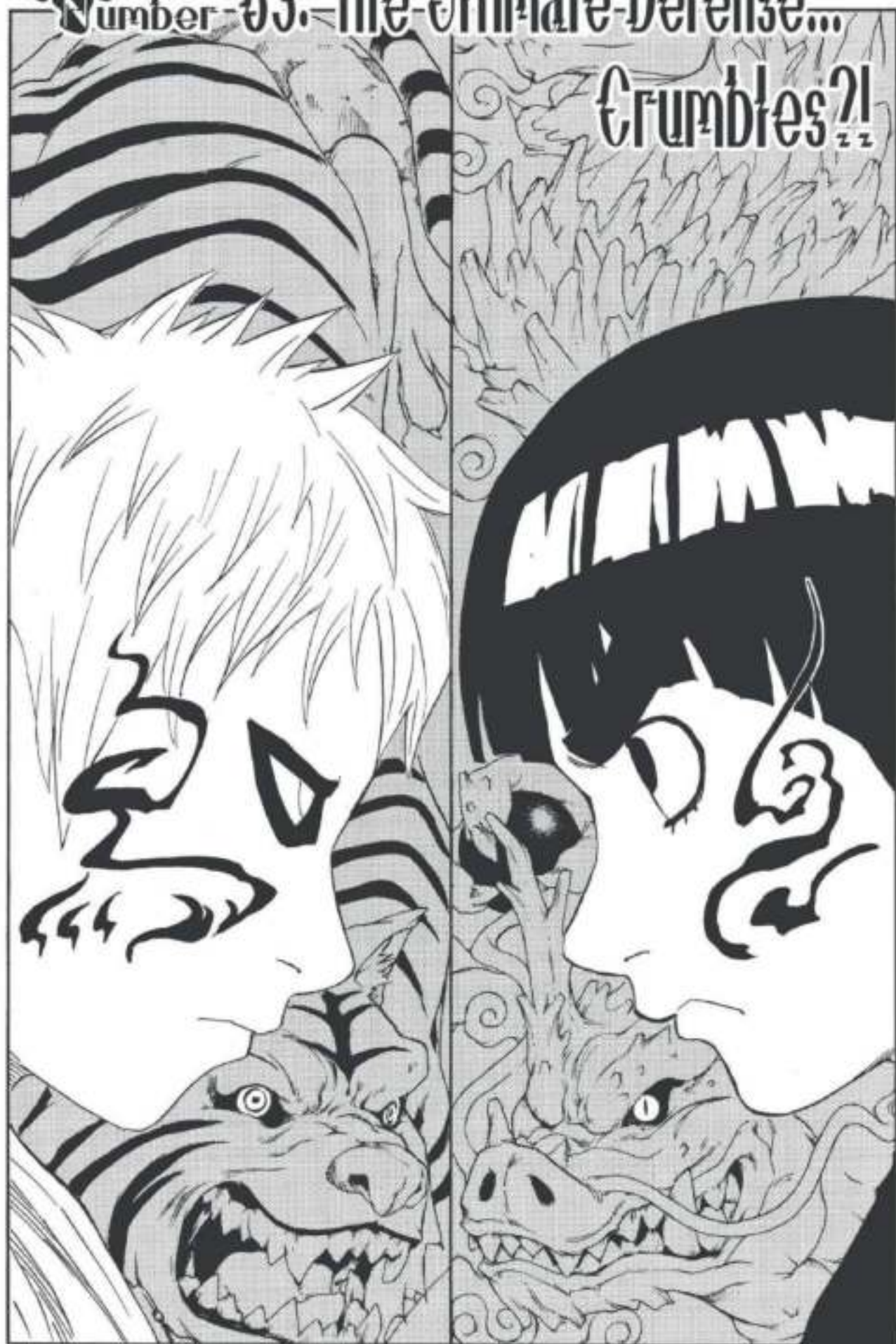













SHIVER!!





IT DIFFERS FROM THE SAND SHIELD, WHERE THE GRAINS AUTOMATICALLY FLOW TO FORM A PROTECTIVE BARRIER...

YES. GAARA CAN CREATE A THIN SHELL OF SAND TO COVER AND PROTECT HIS ENTIRE BODY, CONTROLLING IT BY THE FORCE OF HIS WILL.

SAND SHIELD

SAND ARMOR

...ARMOR?

...THEN... THERE'S NOTHING LEE CAN DO!

IT'S GOT NO WEAKNESSES...!

...ULTIMATE DEFENSE!

IT'S GAARA'S...

IT'S HIS PROTECTION OF LAST RESORT.

THAT'S NOT EXACTLY TRUE. THE SAND ARMOR IS ACTUALLY RIDDLED WITH WEAK POINTS...



ITS DEFENSIVE STRENGTH IS LESS THAN THAT OF THE SAND SHIELD... AND SINCE THE SAND ITSELF IS LYING AGAINST HIS SKIN, IT INCREASES THE WEIGHT OF HIS BODY SO HE MUST EXPEND MORE PHYSICAL STRENGTH JUST TO MOVE.

IT'S NOT AUTOMATIC, THE WAY THE SHIELD IS... IT REQUIRES A MASSIVE OUTPOURING OF CHAKRA.



BUT THE END OF THIS IS A FORE-GONE CONCLUSION...

THAT LEE IS REALLY SOMETHING!



...THEN RIGHT NOW, HIS MIND IS PURELY ON DEFENSE. HE'S BEEN DRIVEN INTO A CORNER...!

IF GAARA HAS BEEN DRIVEN TO USING THE ARMOR...



IS THAT ALL...?



BECAUSE GAARA... IS A GENIUS!!!

READ THIS WAY



MY ONLY SHOT IS TO JUST KEEP POUNDING AND PUNISHING THAT OUTER LAYER OF SAND!

IT'S AN AMAZING DEFENSE! HE'S ENCASED IN PROTECTION, WHICH MAKES MY SPEED IRRELEVANT...









THAT MANY CONSECUTIVE KICKS MAY BE TOO MUCH EVEN FOR LEE... BETTER MAKE YOUR NEXT MOVE A DECISIVE ONE, KID!!

...EVEN AN ORDINARY LOTUS MOVE EXERTS A GREAT STRAIN ON THE USER'S BODY...





FOR-  
WARD  
LOTUS!!

ON



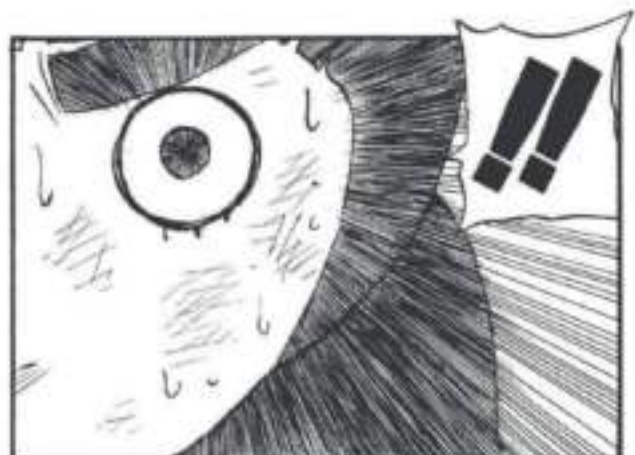



 Number 84: The Genius of Hard Work...!!

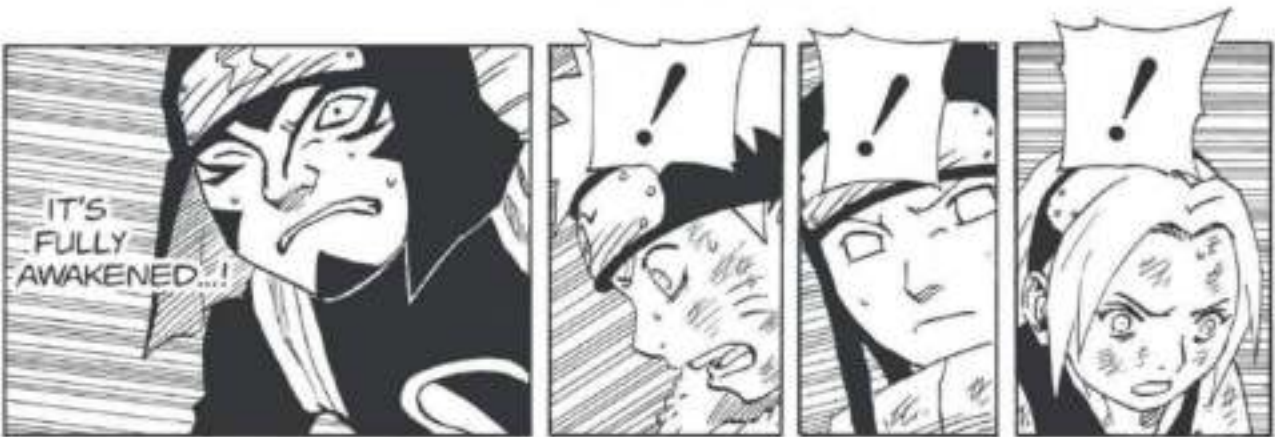



Number 84: The Genius of Hard Work!!

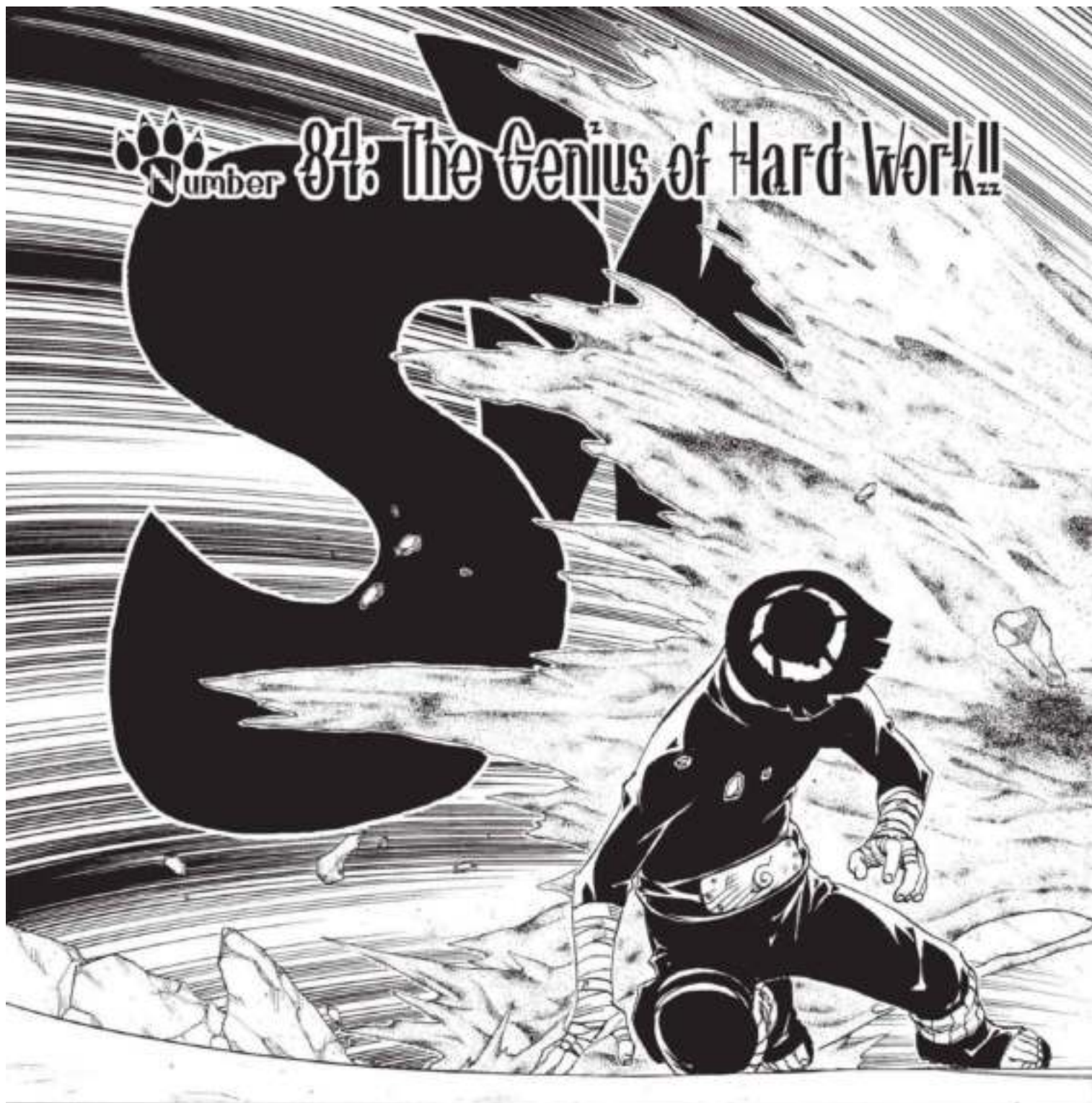









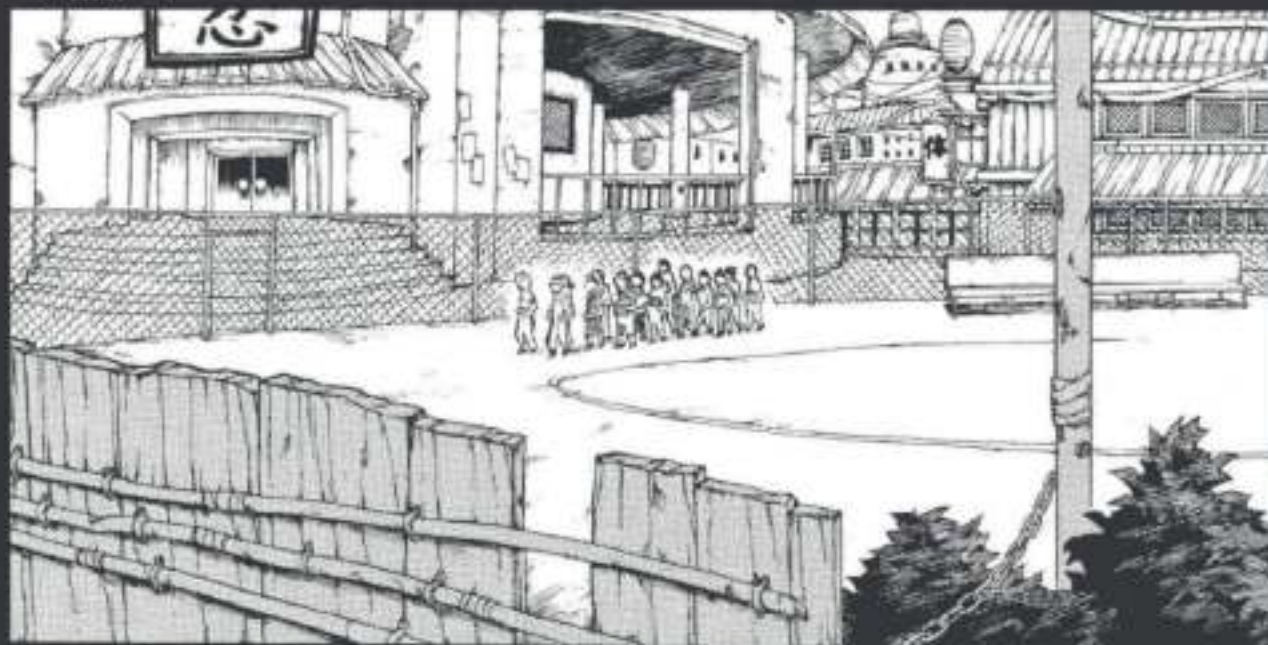

BUT...  
I WILL!!!



YEAH,  
HOW COULD  
SOMEONE WHO  
CAN'T EVEN USE  
NINJUTSU HOPE  
TO BECOME  
A NINJA?

HA HA HA...  
YOU IDIOT!  
THERE'S NO WAY  
YOU'LL EVER  
BE A NINJA!



HEH... WANT TO  
KNOW WHAT  
THE OTHER  
KIDS CALL  
YOU?

NO!



WHAT  
WERE THEY  
THINKING,  
LETTING  
YOU INTO  
THE NINJA  
ACADEMY?

YOU'RE NOT  
CAPABLE OF  
ANYTHING BUT  
TAIJUTSU... AND  
YOU'RE EVEN  
MEDIocre  
AT THAT!

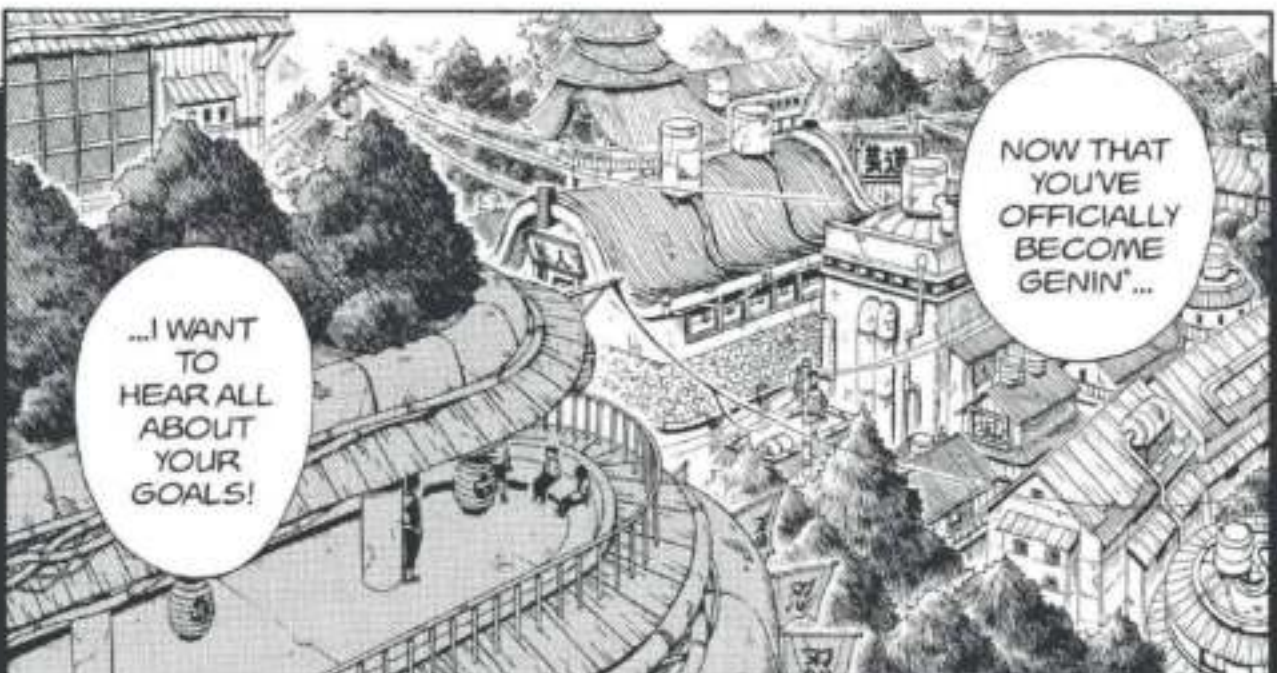



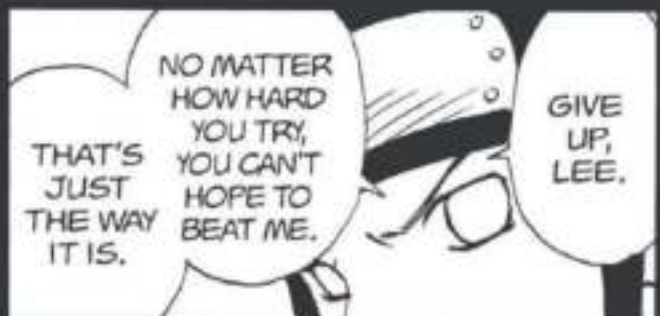









NEVERTHELESS, LEE... THERE'S ONE AREA WHERE YOU COMPLETELY SURPASS NEJI.

YOU'RE A GENIUS OF ANOTHER KIND WITH GREAT HIDDEN POTENTIAL.



YOU KNOW... YOU REALLY ARE VERY DIFFERENT FROM NEJI...

YOU'RE NO GENIUS AT NINJUTSU OR GENJUTSU... AND YOU REALLY AREN'T A TAIJUTSU VIRTUOSO, EITHER.





...A  
GENIUS  
OF  
HARD  
WORK.



....!



...DO  
YOU  
REALLY...

...MEAN  
THAT?



...



...OF EVER  
MEASURING  
UP TO A  
TRUE  
GENIUS  
LIKE NEJI.

BUT...  
LATELY,  
I'VE  
STARTED  
TO FEEL  
THAT I HAD  
NO HOPE...



...BY HAVING  
FAITH THAT,  
IF I TRAINED  
TWO OR THREE  
TIMES AS HARD  
AS NEJI, I MIGHT  
FINALLY BEAT  
HIM.

I'VE  
ALWAYS  
BELIEVED  
THAT.

I... I'VE  
ONLY  
BEEN  
ABLE TO  
MAKE IT  
THIS FAR...

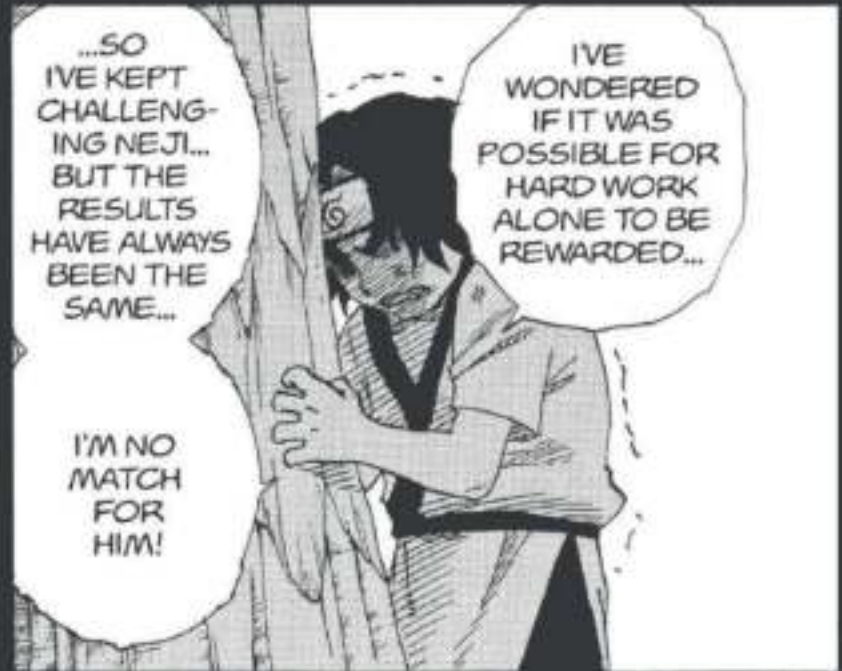



READ THIS WAY

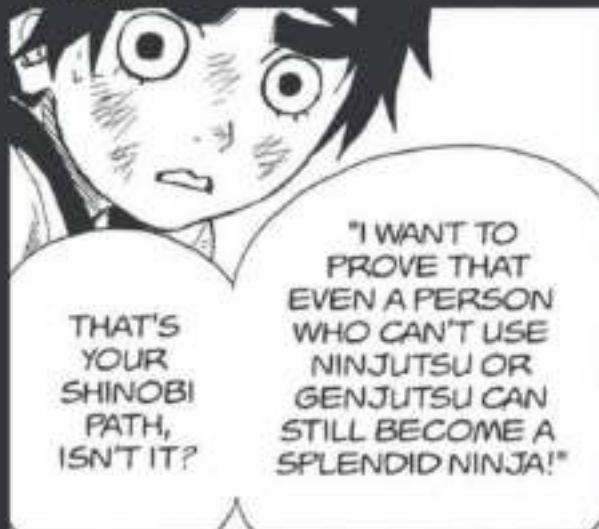



...LEE, NO!  
GIVE UP  
BEFORE  
HE KILLS  
YOU!!

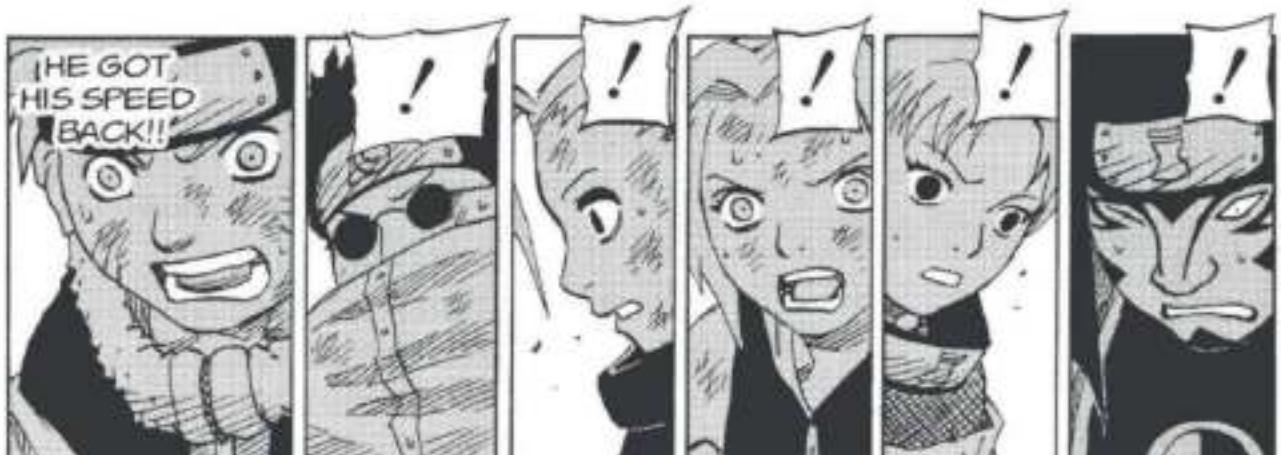

HE GOT  
HIS SPEED  
BACK!!







 Number 85: Now, of All Times...!!











...CAN STILL  
BECOME A  
SPLendid  
NINJA!  
IT'S MY  
ONLY  
GOAL!!

I WANT TO  
PROVE THAT  
EVEN A PERSON  
WHO CAN'T USE  
NINJUTSU OR  
GENJUTSU...

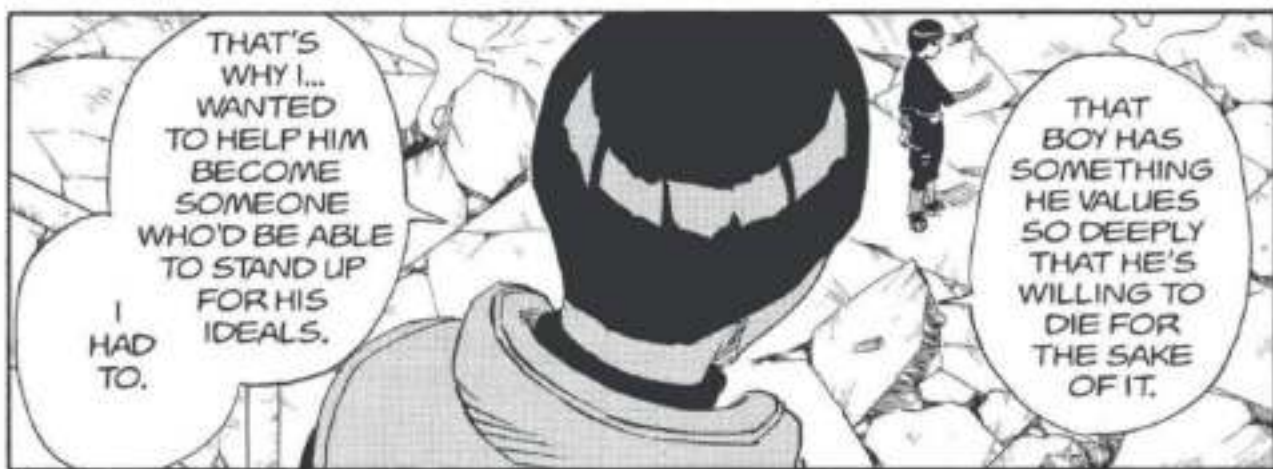

THAT'S  
WHY I...  
WANTED  
TO HELP HIM  
BECOME  
SOMEONE  
WHO'D BE ABLE  
TO STAND UP  
FOR HIS  
IDEALS.  
I  
HAD  
TO.

THAT  
BOY HAS  
SOMETHING  
HE VALUES  
SO DEEPLY  
THAT HE'S  
WILLING TO  
DIE FOR  
THE SAKE  
OF IT.



OH  
BOY...  
\_THIS  
IS  
GREAT!!!

YOU  
BET  
I DID!!

LEE,  
DID YOU  
HEAR  
ME?



SNAP  
OUT OF  
IT AND  
PAY  
ATTENTION!!!

LEE!



...A MOVE  
THAT CAN  
BECOME  
YOUR ACE  
IN THE  
HOLE.

HUNH?

...LEE...  
I'D LIKE TO  
SHOW YOU  
SOMETHING  
NEW...



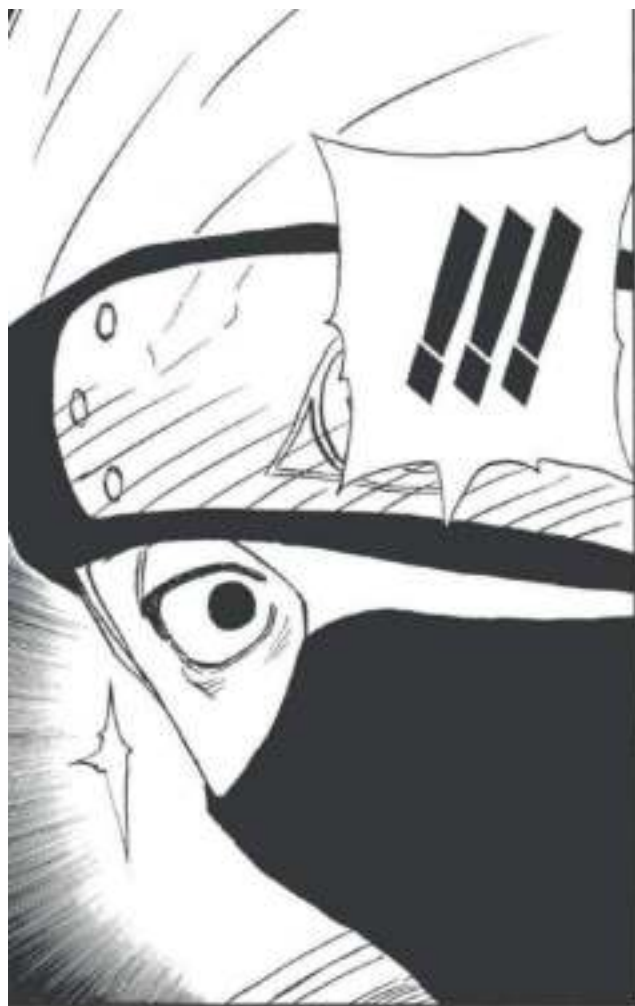

SO TELL ME, GUY... WHICH OF THE EIGHT INNER GATES HAS HE GOTTEN UP TO SO FAR?

SO HE WAS ABLE TO BOUNCE BACK FROM EXHAUSTION WITH SUCH ABNORMAL SPEED BECAUSE HE'D FORCED OPEN THE KYUMON -- THE GATE OF REST.

THE FIFTH GATE.



WH... WHAT ARE YOU BOTH TALKING ABOUT?!

YOU KEEP MENTIONING THESE... INNER GATES?



SO... THE BOY'S A GENIUS AFTER ALL.

THAT FEAT SHOULD BE IMPOSSIBLE TO ACHIEVE THROUGH HARD WORK ALONE...



?!



LIMITERS... RELEASED?

THE GATES ACT AS LIMITERS THAT MUST BE RELEASED IN PREPARATION FOR PERFORMING THE REVERSE LOTUS.



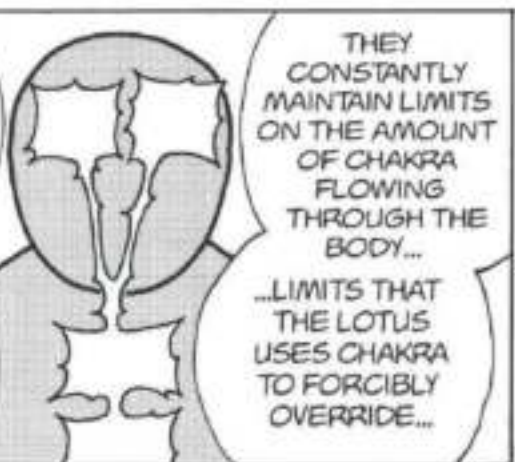
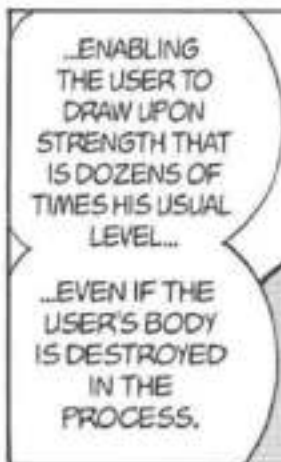
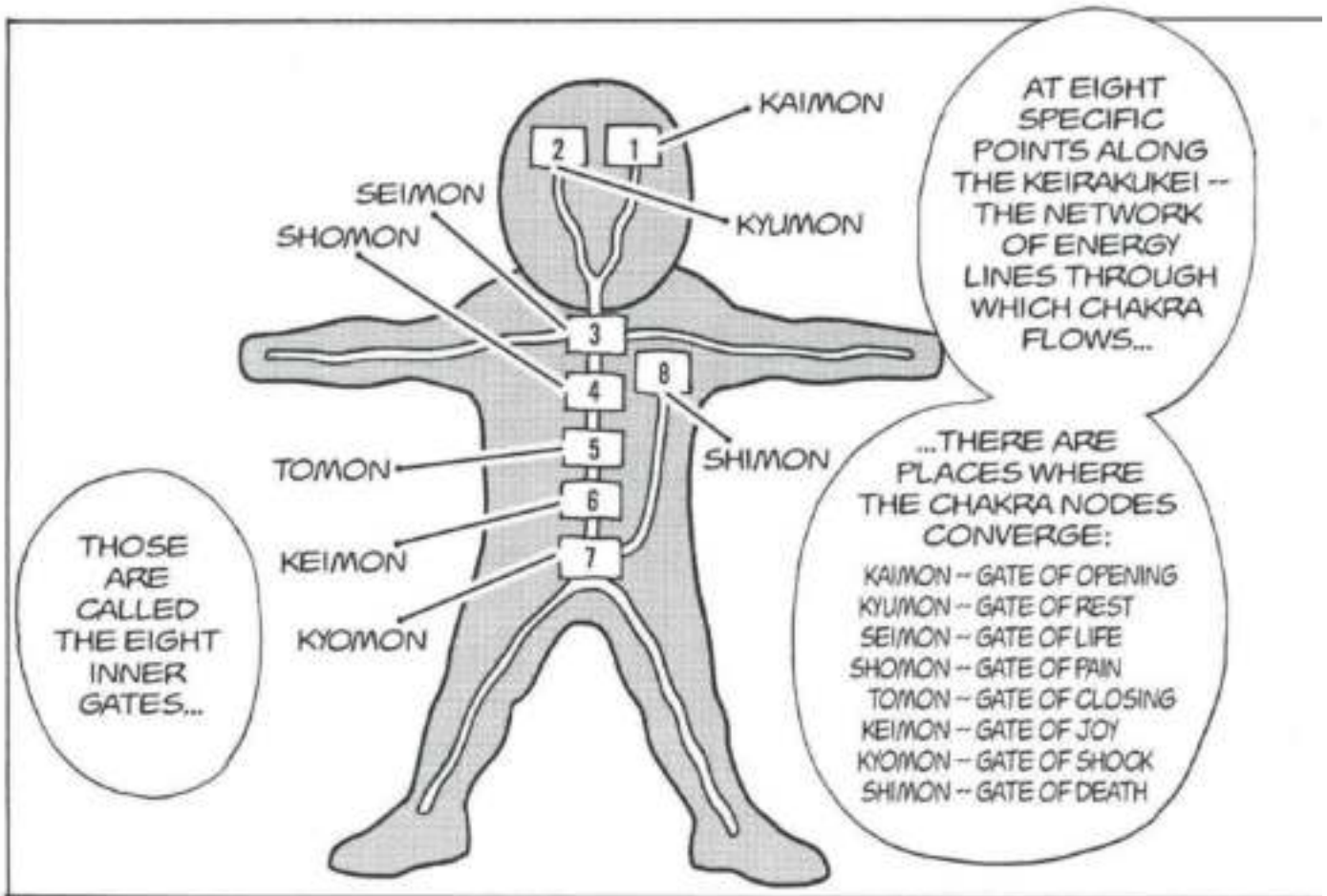
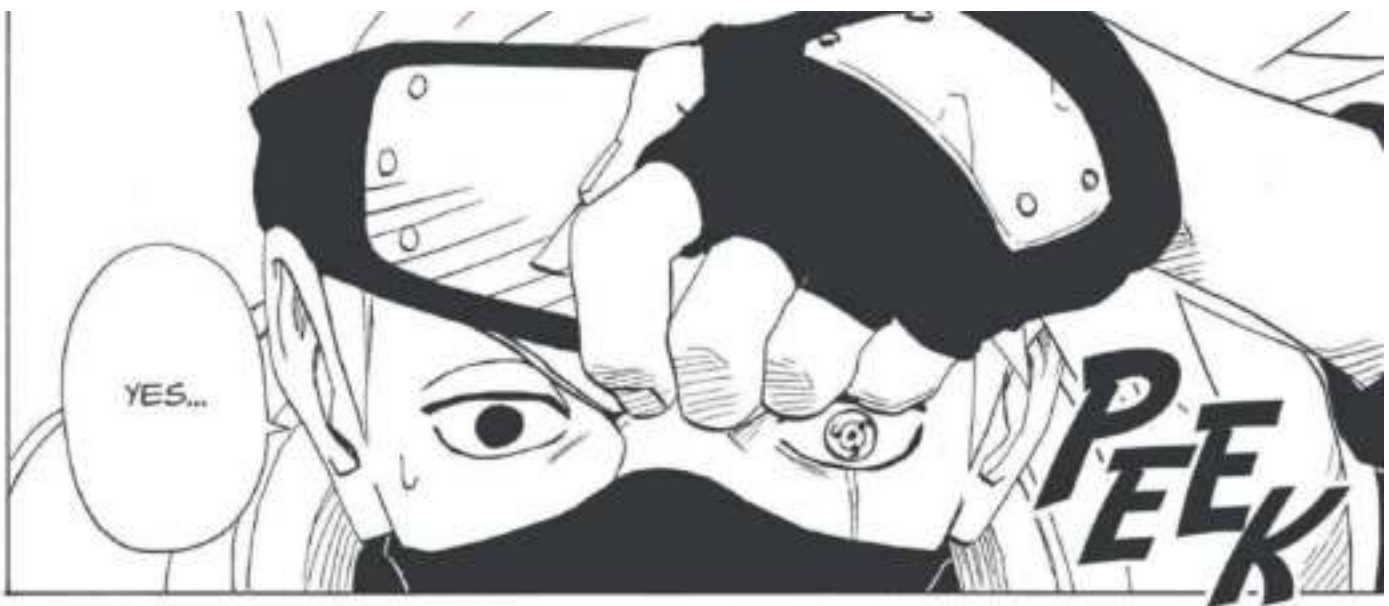



...AND WITH THE OPENING OF THE THIRD GATE - THE SEIMON - ONE CAN BEGIN THE REVERSE LOTUS...

OPENING THE KAIMON FREES THE USER FROM HIS OWN MENTAL INHIBITIONS. THE OPENING OF THE KYUMON BOOSTS HIS STRENGTH...



AND... THE REVERSE LOTUS?

...!



THE STATE WHERE ALL THE GATES HAVE BEEN OPENED IS CALLED THE "EIGHT INNER GATES FORMATION"...

...AND ANYONE WHO ACHIEVES THAT STATE WILL, HOWEVER BRIEFLY, BE GRANTED STRENGTH THAT SURPASSES EVEN THE HOKAGE'S. BUT IN EXCHANGE...

THAT'S RIGHT... THIS TECHNIQUE TRULY IS A DOUBLE-EDGED SWORD.



...IF HE TRIES TO PERFORM ANY MORE MOVES...

BUT... THE FORWARD LOTUS ALONE GOT HIM SO BEATEN UP...



!!

...THAT PERSON WILL INEVITABLY DIE!





...MY  
SHINOBI  
PATH!!!

...NOW,  
WHEN

FINALLY  
ATTAIN...

THE  
THIRD  
GATE,  
SEIMON...  
RELEASE!!



HE'S  
GOING  
TO  
MAKE  
HIS  
MOVE!

HE  
OPENED  
THE  
SEIMON...



...IT'S  
RED?!



THE  
COLOR  
OF  
HIS  
SKIN!











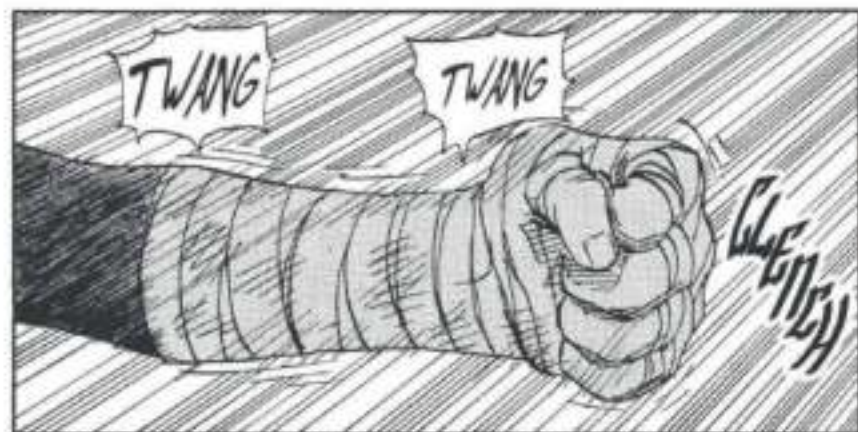



THE WORLD OF KISHIMOTO MASASHI  
MY PERSONAL HISTORY, PART 12

IN MIDDLE SCHOOL, I WAS SO FOCUSED ON BASEBALL THAT I ALMOST STOPPED DRAWING COMPLETELY. THERE WERE GAMES EVERY SATURDAY AND SUNDAY, AND PRACTICE EVERY WEEKDAY MORNING. EVEN MY AFTER-SCHOOL TIME WAS FILLED WITH HOURS OF CRAM SCHOOL, SO I WAS ALWAYS INCREDIBLY BUSY. IT WAS LIKE ANOTHER WORLD COMPARED TO ELEMENTARY SCHOOL, AND ALL OF THE TIME I HAD ONCE SPENT DRAWING WAS GONE.

ONE DAY, JUST WHEN I WAS STARTING TO THINK, "MAYBE I'VE OUTGROWN THE URGE TO BE DRAWING ALL THE TIME," I HAD A SUDDEN AND INCREDIBLE REVELATION. IT WAS SO AMAZING THAT I STILL LOOK BACK ON THAT MOMENT AS A HUGE TURNING POINT. THE AMAZING MOMENT OCCURRED WHEN I SAW A MOVIE POSTER.

I WAS ON MY WAY HOME ONE DAY WHEN I HAPPENED TO GLANCE AT A POSTER FOR OTOMO KATSUHIRO'S *AKIRA*.

IN AN INSTANT, THE SIGHT OF IT HAD AN IMPACT ON ME SO POWERFUL THAT EVEN NOW IT'S HARD TO DESCRIBE. I STOOD STARING AT IT FOR OVER AN HOUR. THE POSTER FEATURED AN OVERHEAD SHOT OF THE MAIN CHARACTER, KANEDA, WALKING TOWARDS A MOTORCYCLE. THE COMPOSITION OF IT WAS INCREDIBLY COMPLEX. "HOW DID THIS GUY DRAW ANYTHING SO COMPLICATED THAT WELL?" "I'VE NEVER KNOWN ANYONE WHO COULD HAVE MADE THAT COMPOSITION WORK..."

DESPITE THE TRICKY ANGLES OF THE PERSPECTIVE, THE BIKE AND KANEDA WERE BOTH DRAWN PERFECTLY, WITH ALL THE SPATIAL RELATIONSHIPS CORRECT. THE SENSE THAT KANEDA WAS ACTUALLY STANDING SOLIDLY ON THE GROUND WAS CONVEYED IN A WAY THAT SEEMED TOTALLY REAL AND COOL. THE BIKE HAD AN AMAZING DESIGN, AND THERE WERE CRACKS IN THE GROUND AND PEBBLES SCATTERED ABOUT, SEEMINGLY AT RANDOM. THAT POSTER SEEMED LIKE THE COOLEST, MOST ORIGINAL THING I HAD EVER SEEN AND IT REKINDLED THE FLAME OF MY ARTISTIC PASSION. EVER SINCE THAT DAY, I'VE KEPT DRAWING WITH THE HOPE THAT SOMEDAY I CAN APPROACH THE STANDARD SET BY THAT PICTURE.



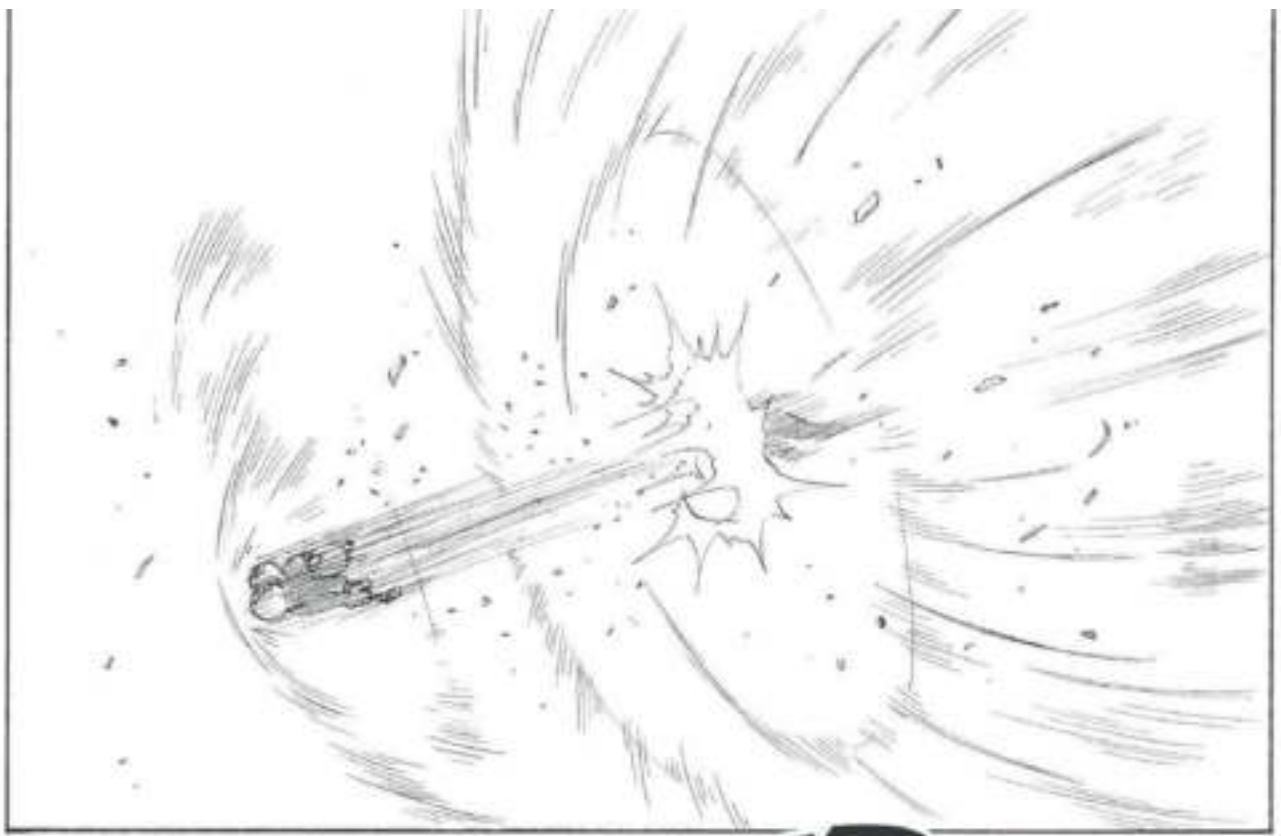



THESE RAPID MOVES ARE LEE'S KEY TO WINNING THE MATCH...

THE REVERSE LOTUS... A SERIES OF TAIJUTSU PERFORMED WITH SUCH SPEED THAT THE ATTACKER IS UNTOUCHABLE!

THERE'S NO WAY THE SAND CAN CATCH UP...!!

MUCH OF THE SAND ARMOR HAS BEEN TORN AWAY...

THE SAND SHIELD CAN'T KEEP UP...

THIS IS NOT GOOD...!!



HYAH!!



 Number 86:

**REVERSE  
LOTUS!!!**



**A Splendid Ninja...!!**







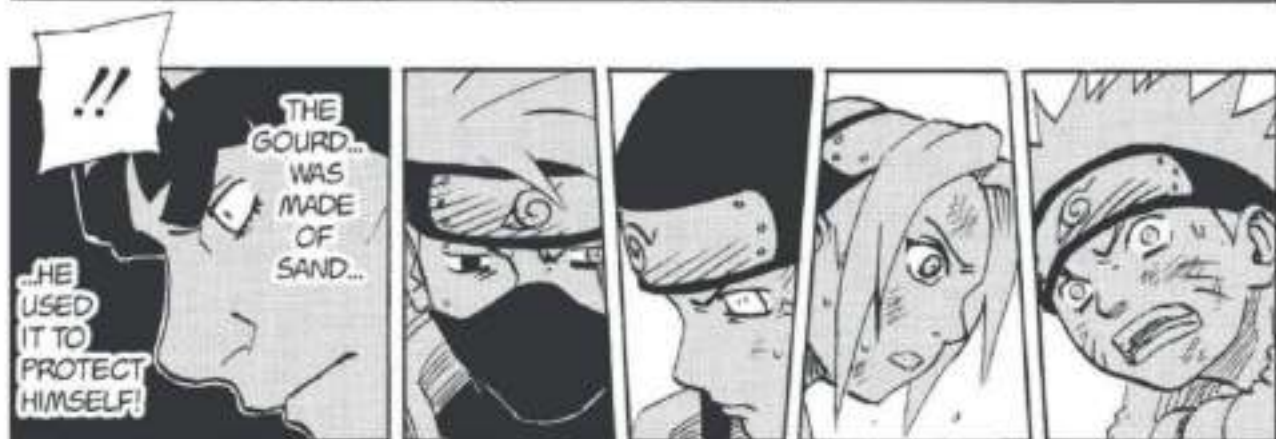









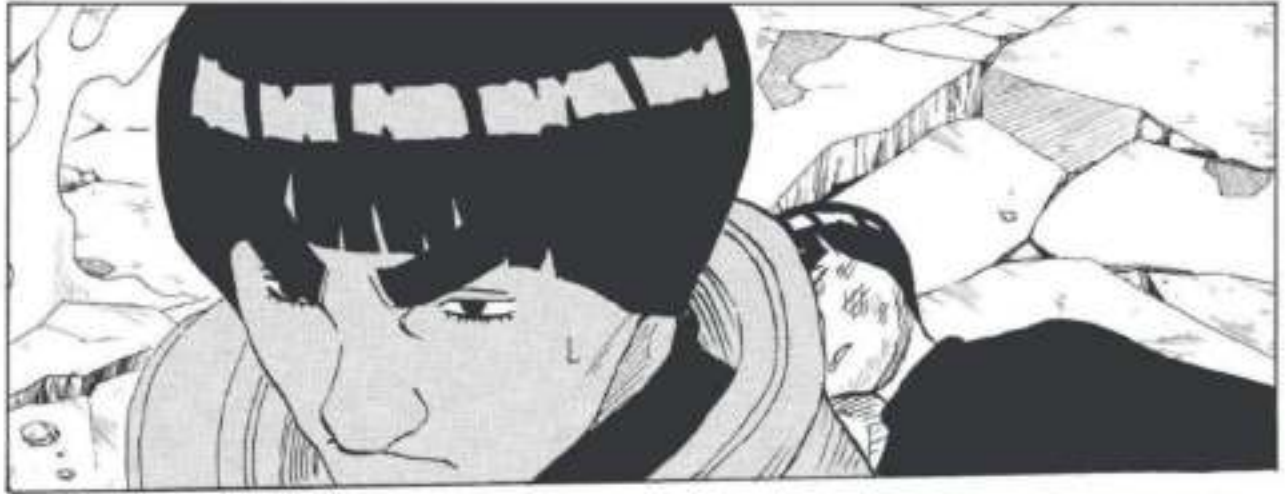











...TRYING  
TO STAY  
TRUE TO  
YOUR  
SHINOBI  
PATH...



EVEN THOUGH  
YOU'VE BEEN  
KNOCKED  
SENSELESS,  
YOU'RE STILL...







• THIS CHARACTER IS FROM AN UNPUBLISHED WORK  
I DID PRIOR TO NARUTO.

 Number 87: The Preliminaries...  
Completed!!



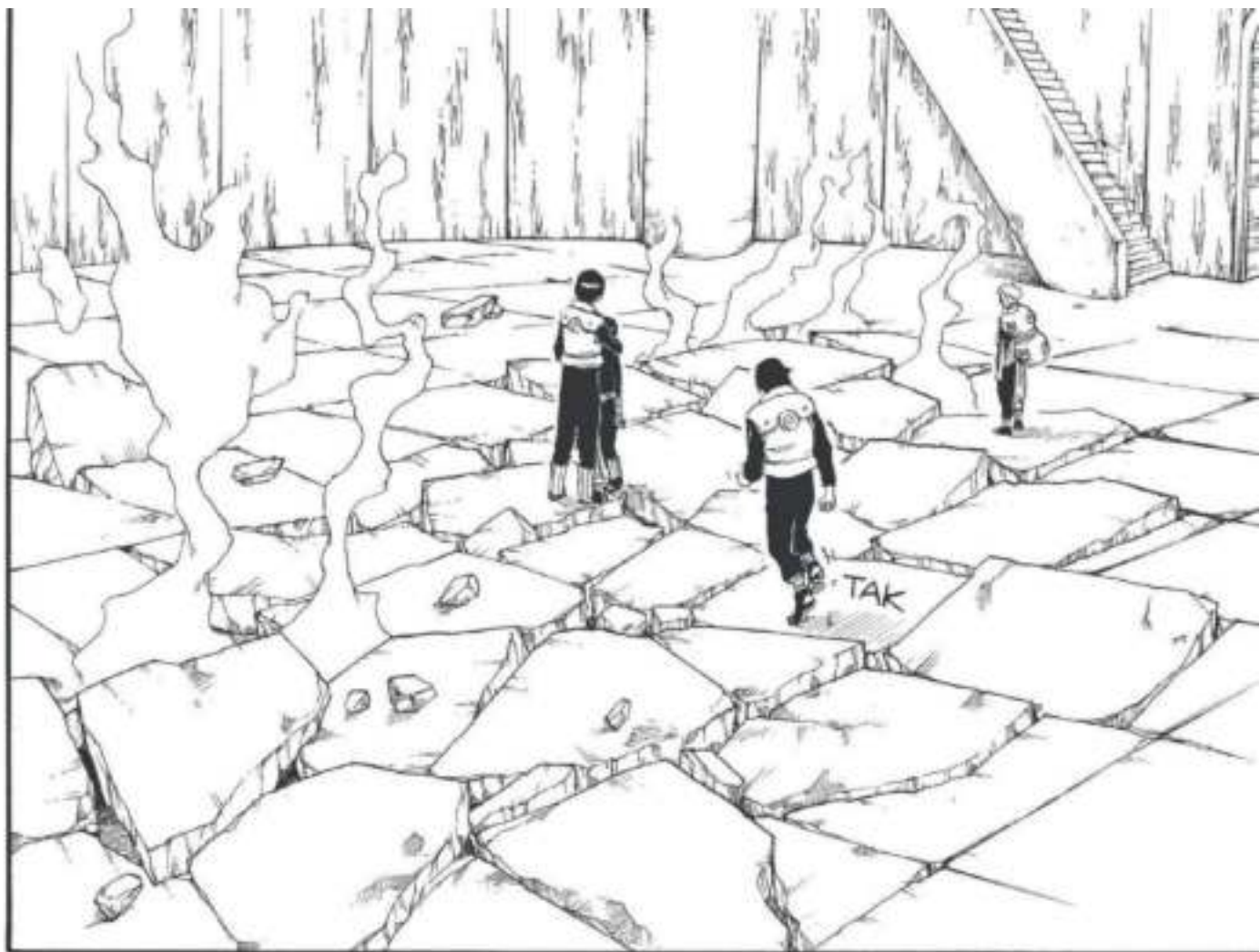





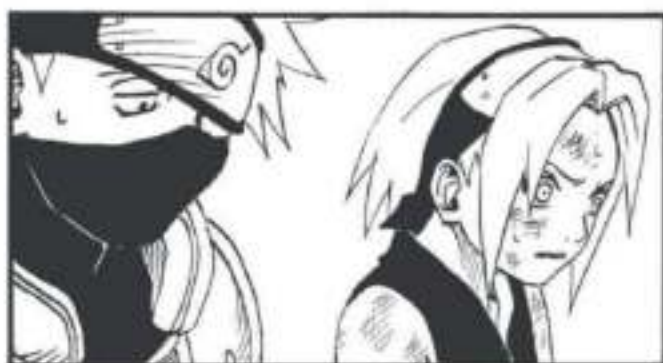
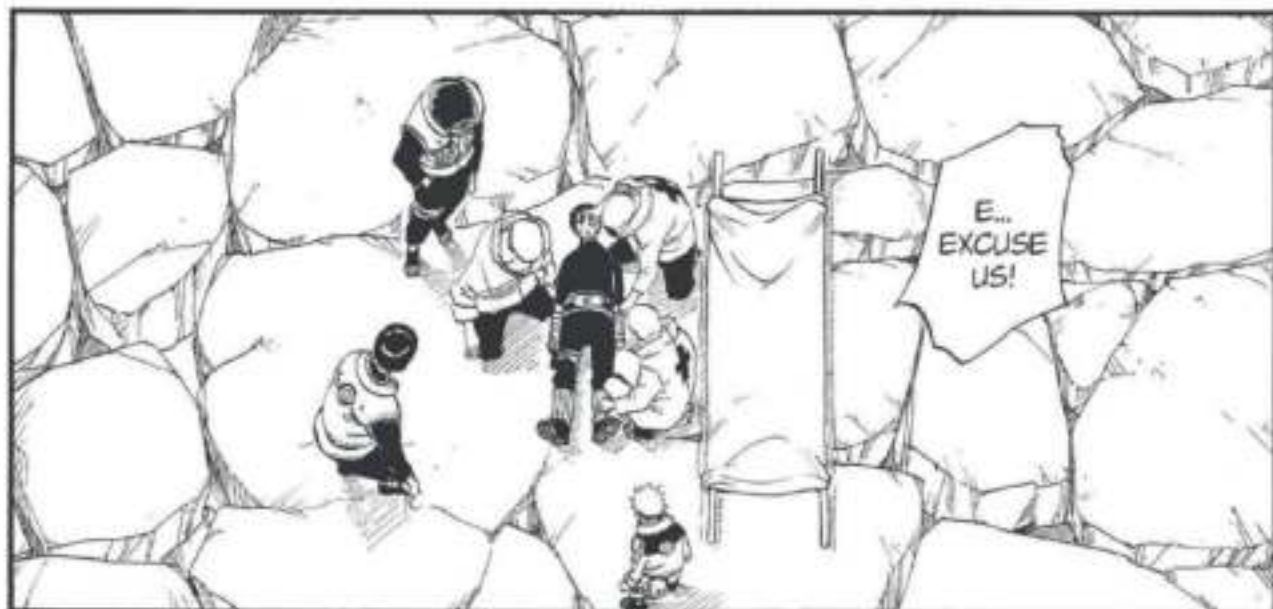







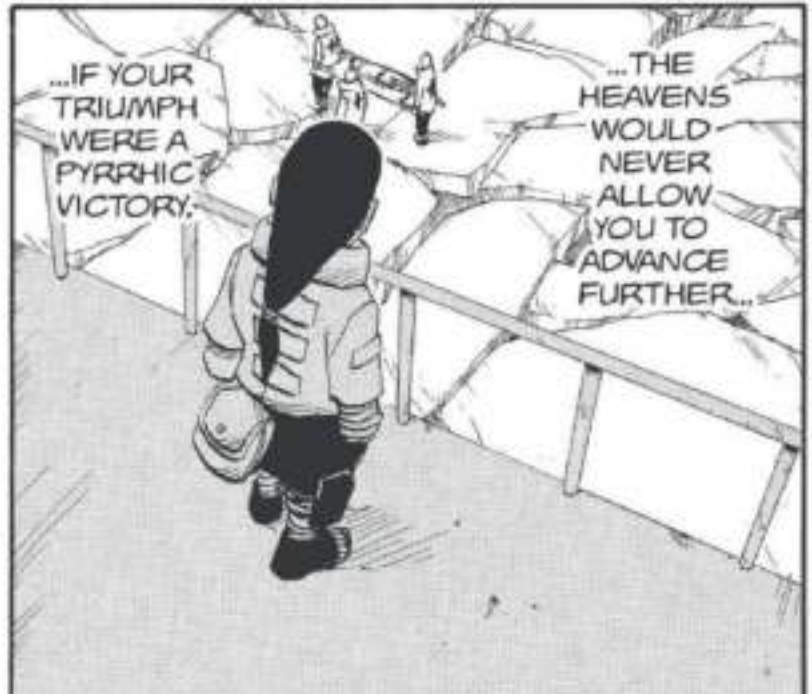

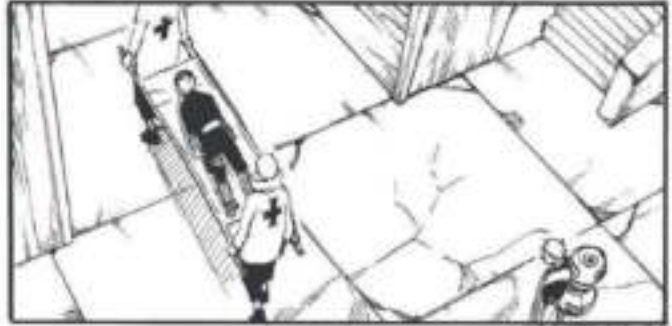

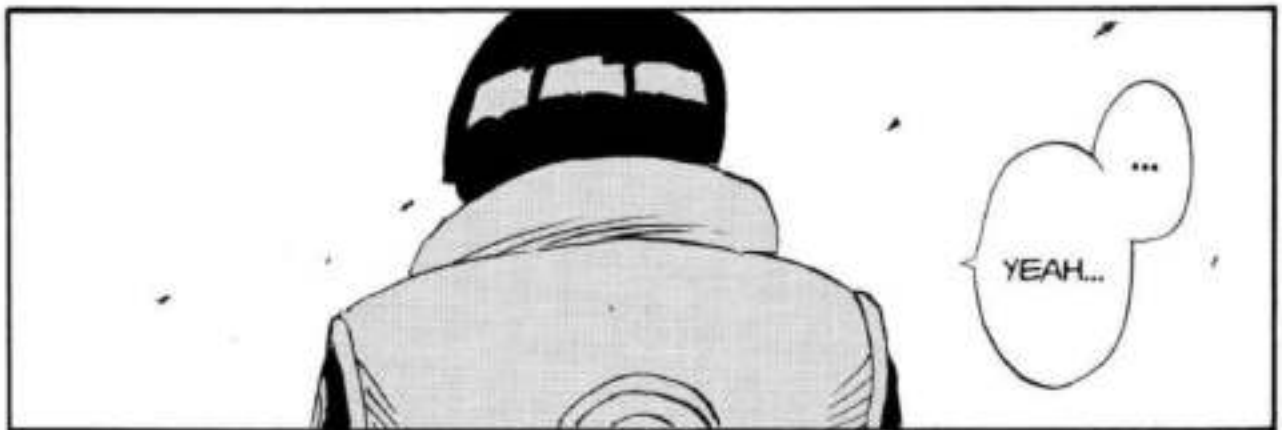

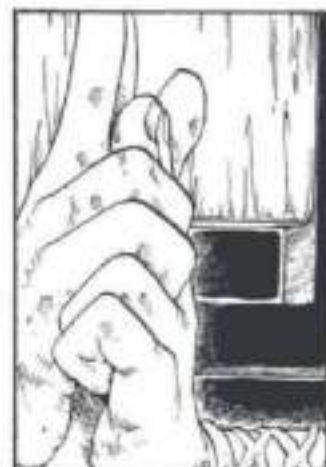

























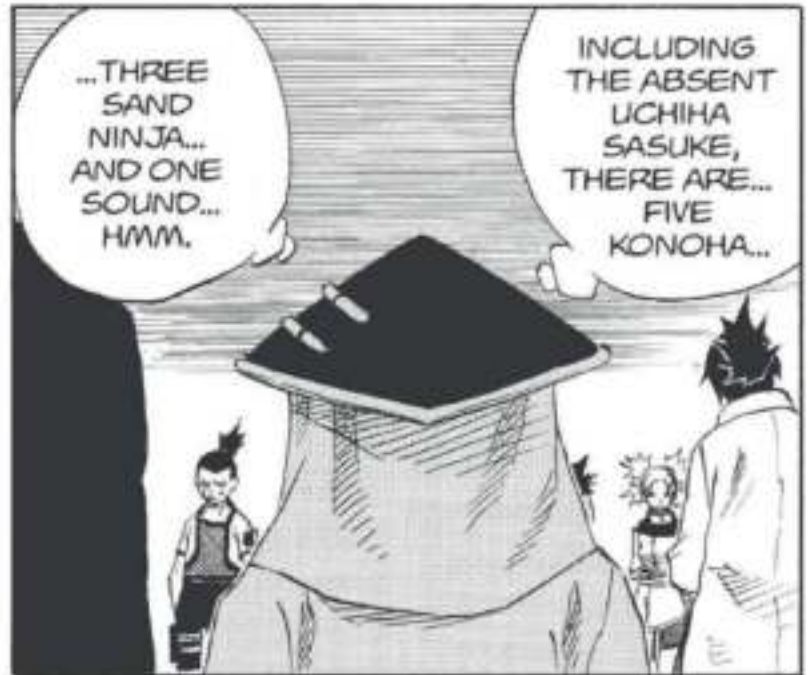

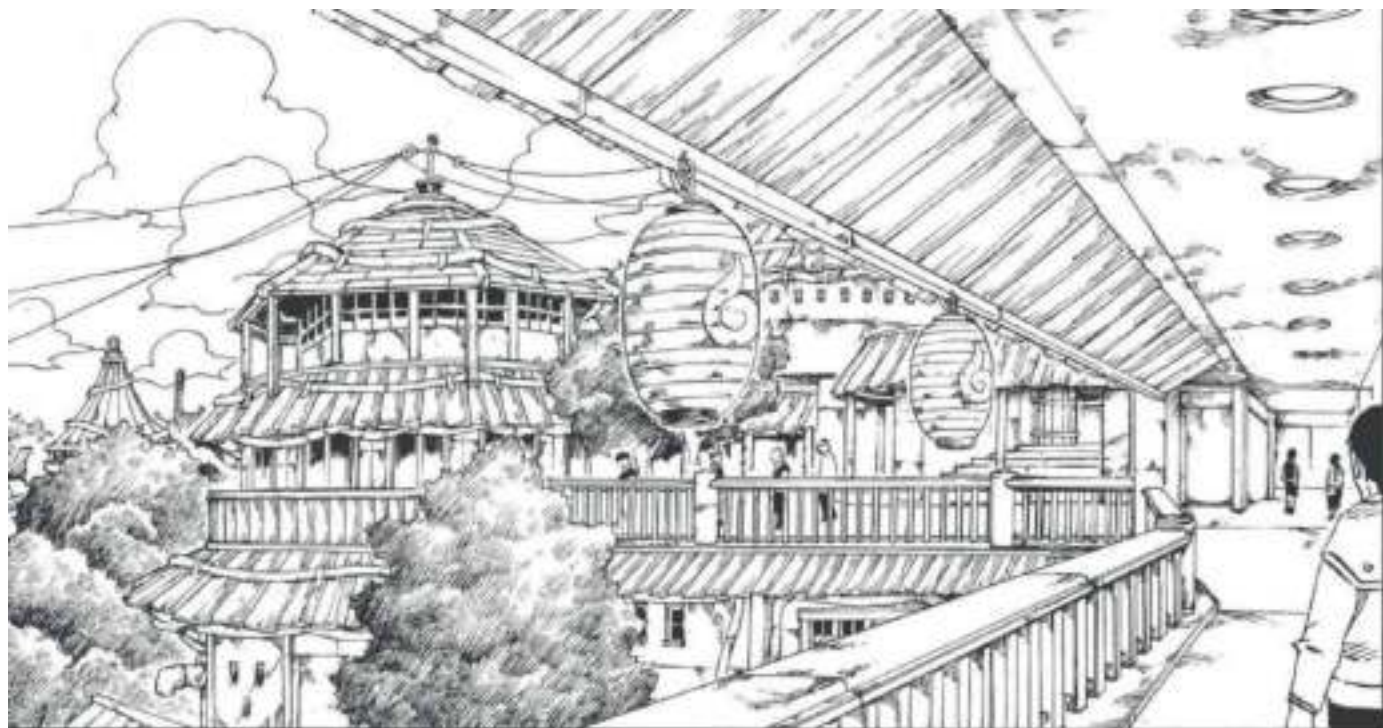

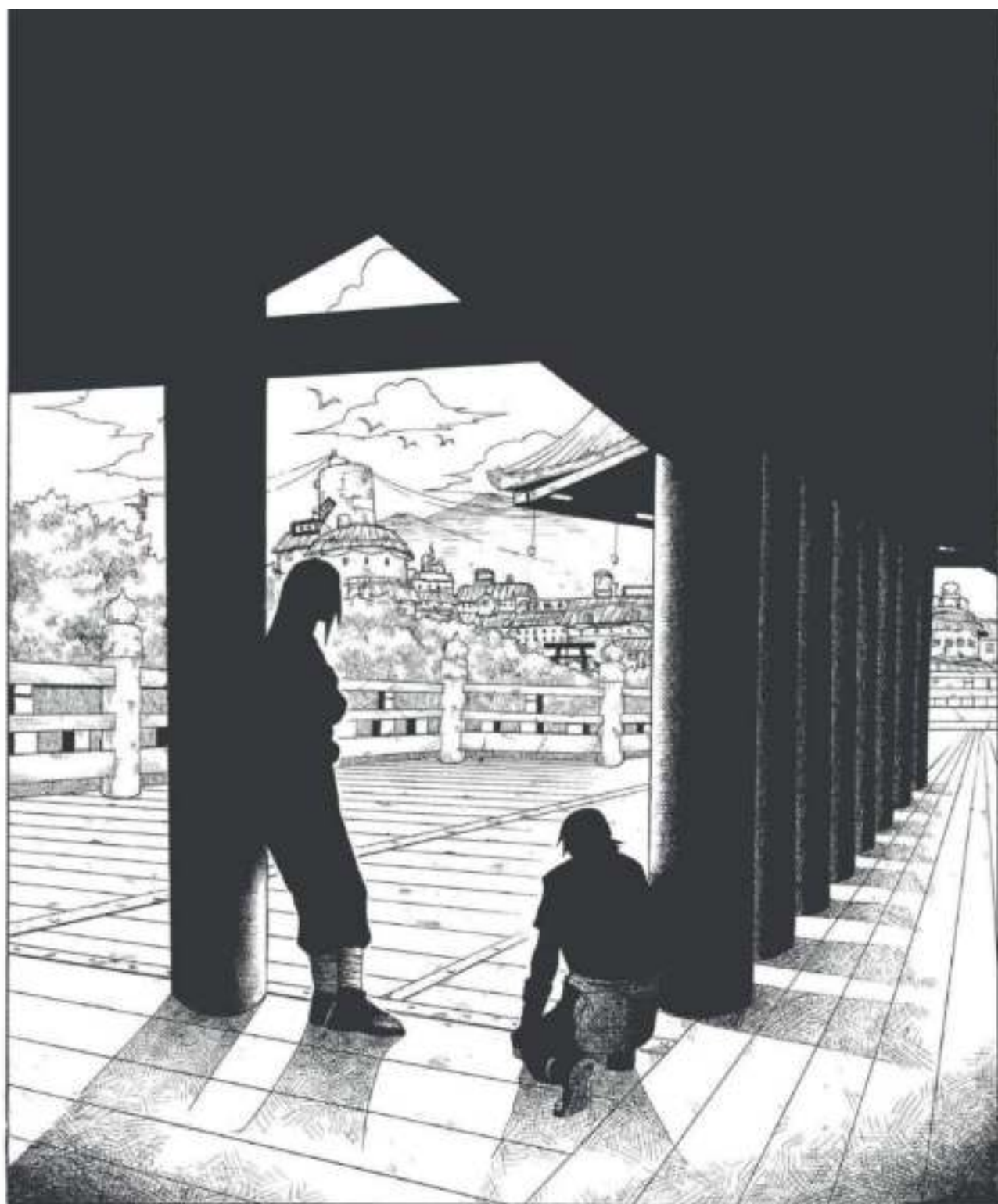





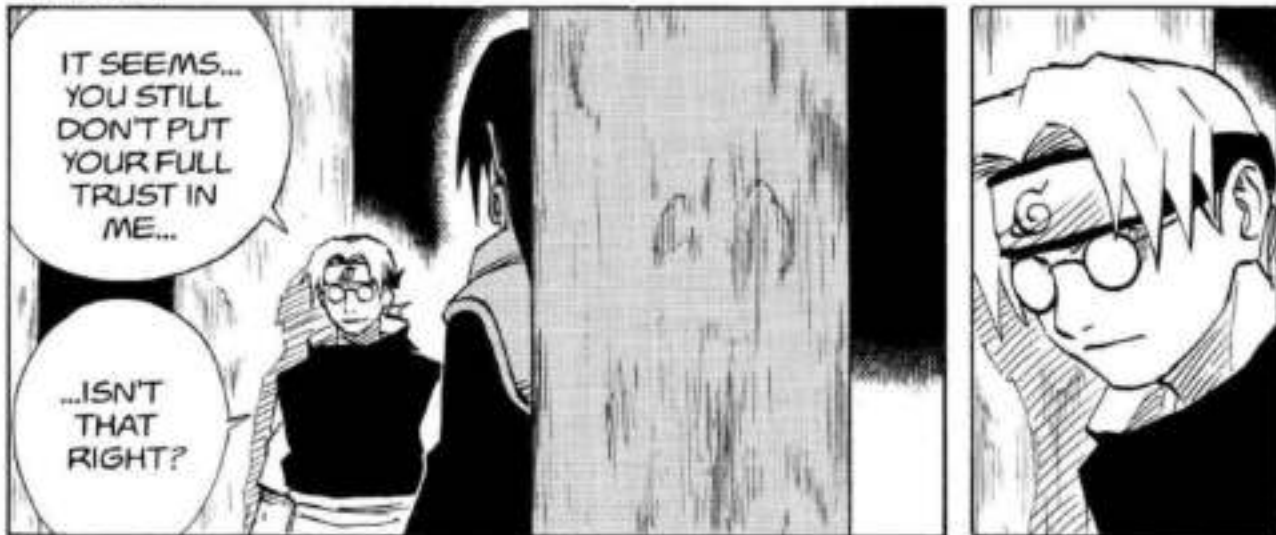









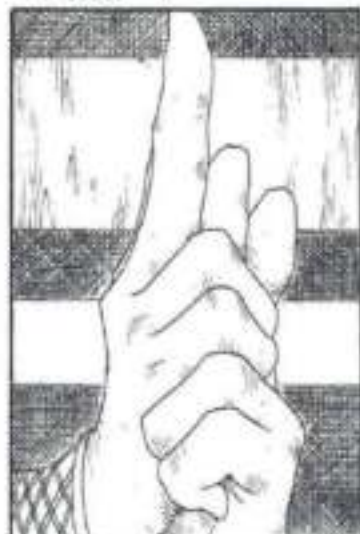

WONDER WHAT HE'S THINKING...

HEH... THAT FACE...



EACH OF YOU REPRESENTS THE BATTLE STRENGTHS OF YOUR RESPECTIVE LANDS...

...SO WE WANT YOU TO EXHIBIT AND FULLY SHOWCASE YOUR VARIOUS TALENTS.

AS I MENTIONED EARLIER, YOU WILL CONDUCT YOUR FINAL ROUND BATTLES IN FRONT OF EVERYONE.



...WILL COMMENCE ONE MONTH FROM NOW!

AND THUS THE FINALS...



WHAT DO YOU MEAN?

WE CALL THIS THE REQUISITE PREPARATION PERIOD...



WE'RE NOT DOING IT RIGHT HERE, RIGHT NOW?



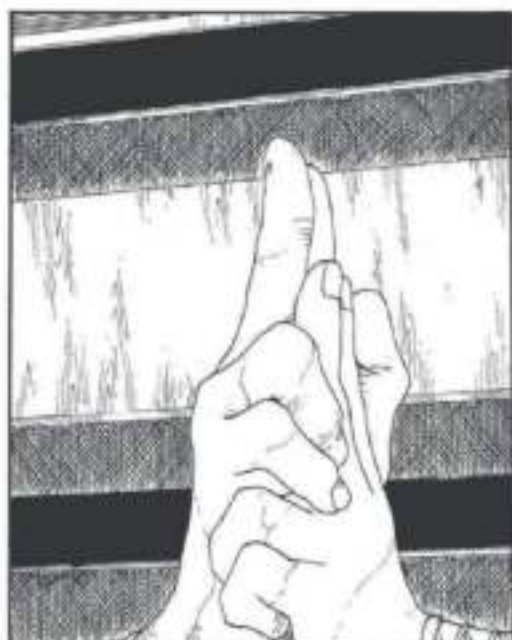

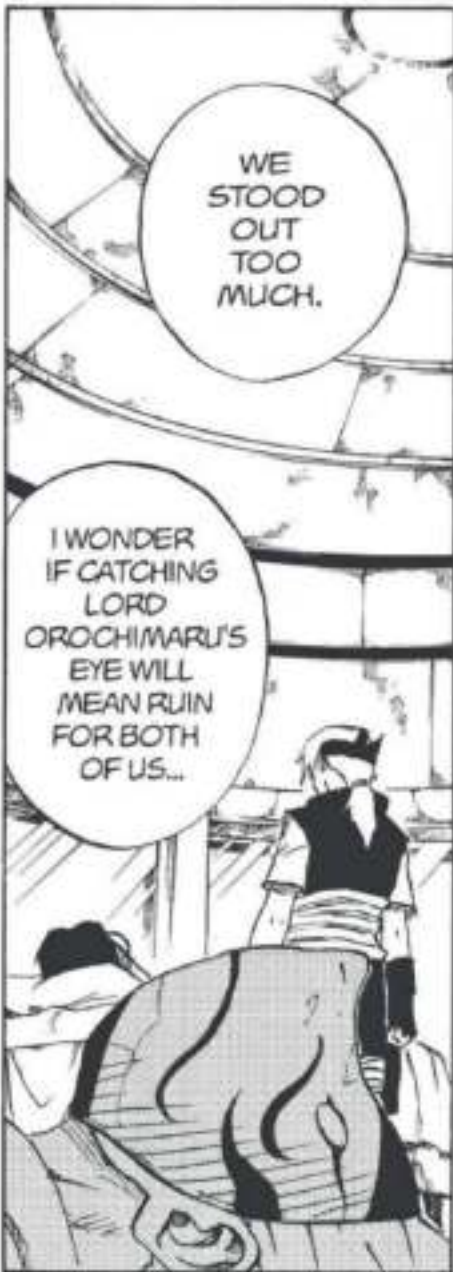

WE  
STOOD  
OUT  
TOO  
MUCH.

I WONDER  
IF CATCHING  
LORD  
OROCHIMARU'S  
EYE WILL  
MEAN RUIN  
FOR BOTH  
OF US...



AN  
EXCESS OF  
BRILLIANCE  
CAN BE A  
DISADVANTAGE...

TAK

TAK

SIGH...











 Number 89:

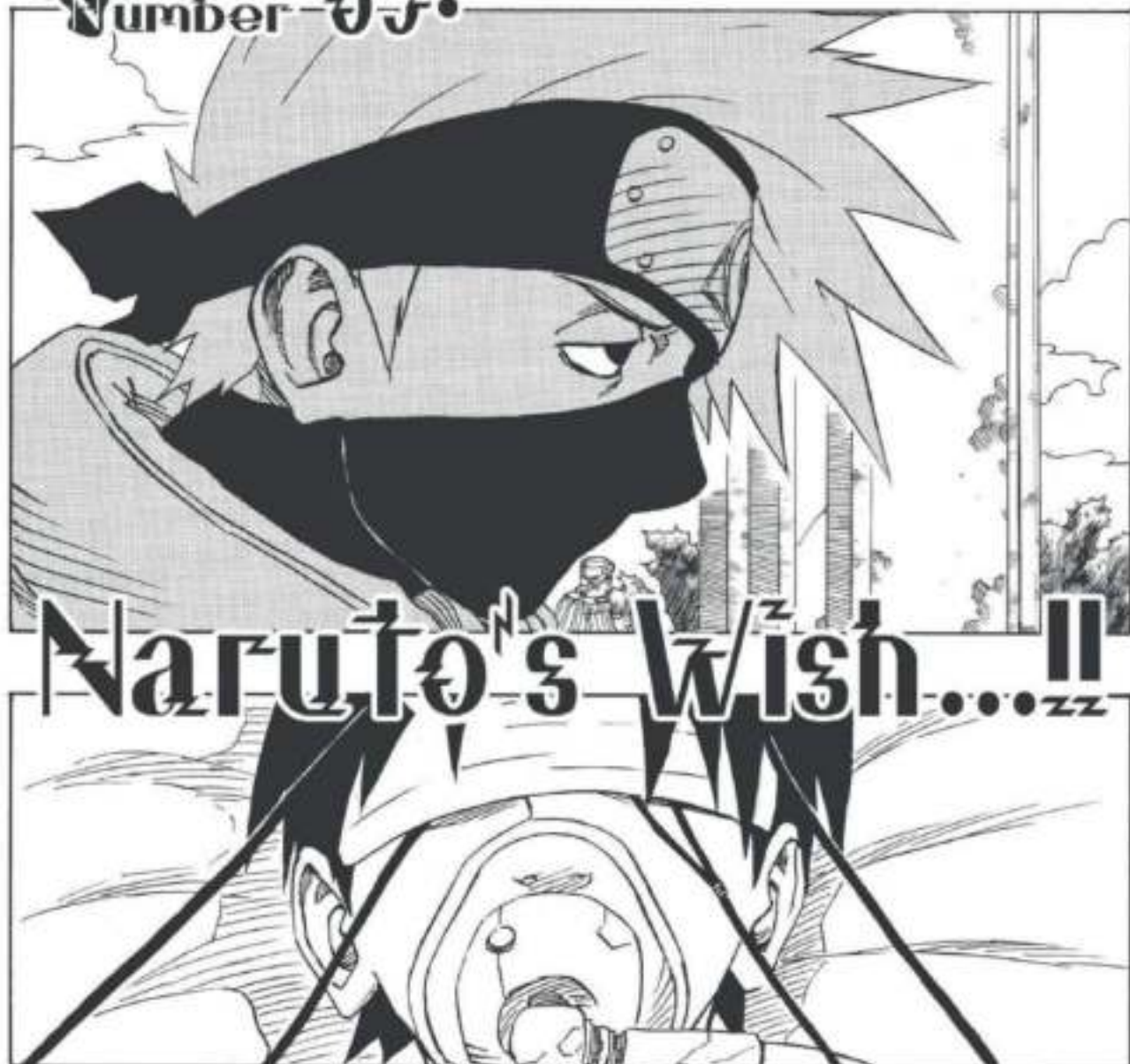





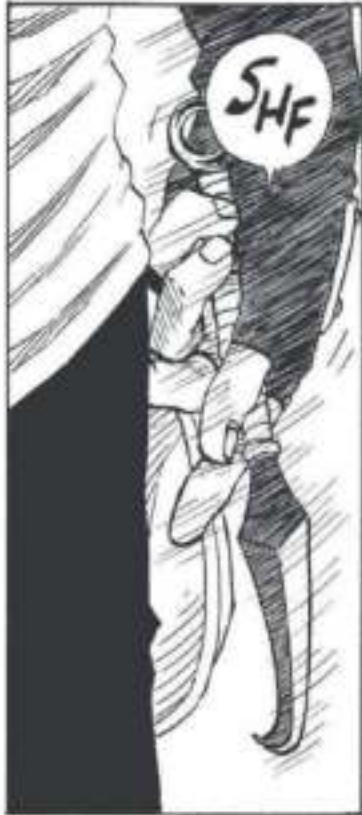

YOU'RE ACTING AWFULLY SMUG, CONSIDERING...

YOU KNOW THE LAWS OF THIS VILLAGE...

...HOW SPIES ARE DEALT WITH.















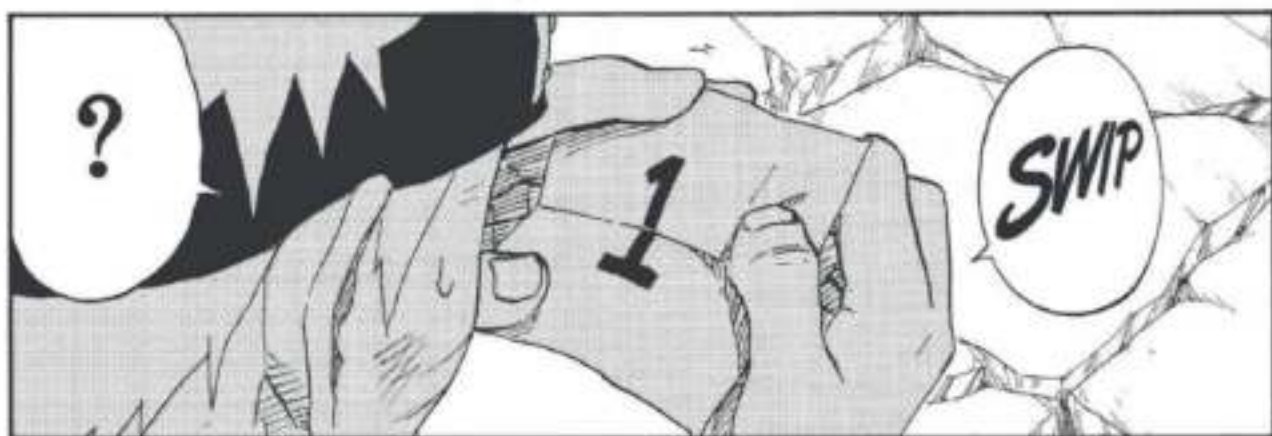



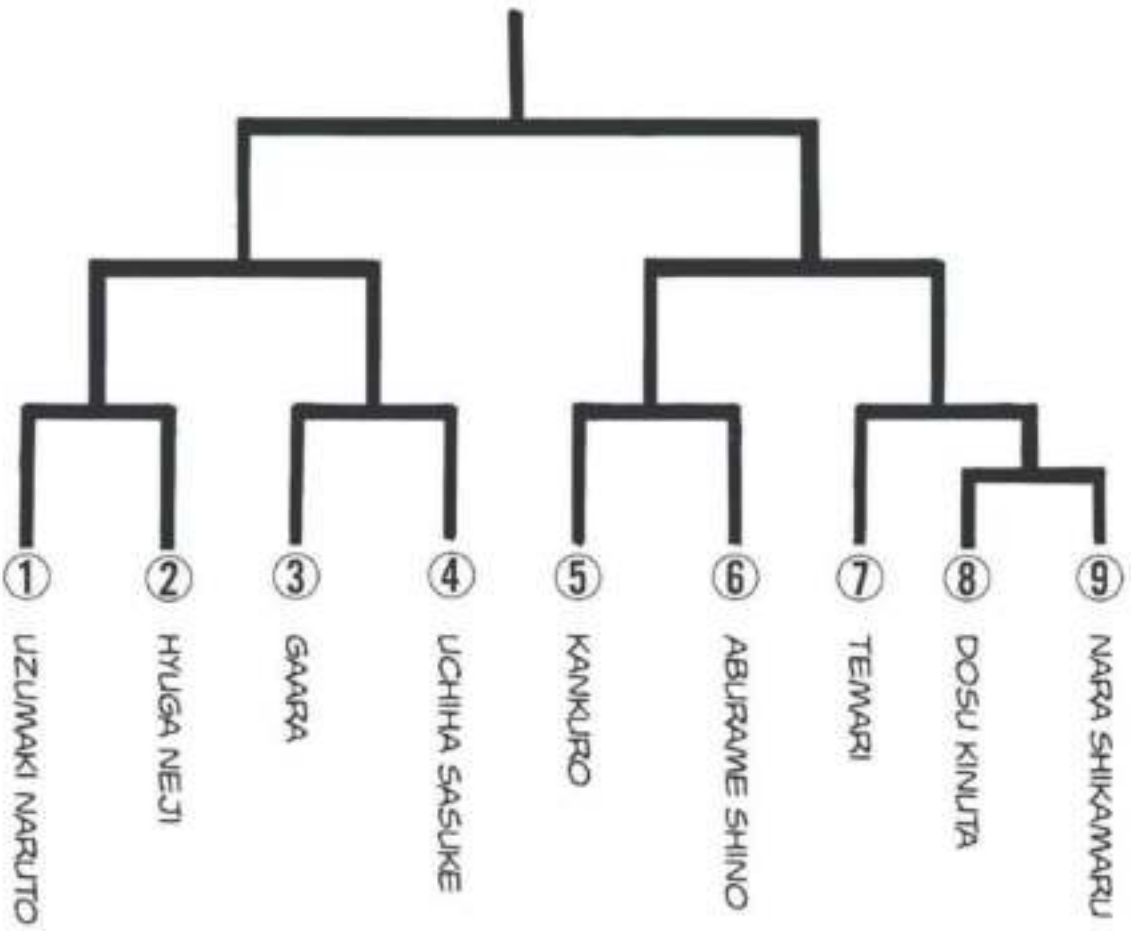







\*THE LEADER OF THE VILLAGE OF SUNAGAKURE (THE VILLAGE HIDDEN IN SAND).











THE WORLD OF KISHIMOTO MASASHI  
MY PERSONAL HISTORY, PART 13

ONCE I WAS EXPOSED TO *AKIRA*, MY ATTITUDE TOWARD ART BEGAN TO CHANGE DRAMATICALLY. I DID SOME RESEARCH ON THE STYLE OF MR. OTOMO, THE AUTHOR AND ARTIST OF *AKIRA*, IN AN ATTEMPT TO LEARN WHICH ARTISTS HAD INFLUENCED HIM... BUT I COULDN'T FIND ANYTHING. SO I CONCLUDED THAT IT WAS COMPLETELY ORIGINAL... AND THAT'S WHEN IT CAME TO ME: "WOW, THIS IS THE FIRST TIME SINCE SEEING MR. TORIYAMA'S WORK THAT I'VE BEEN SO STRONGLY AFFECTED BY SOMEONE'S ART."

I HAD ABSOLUTELY NO IDEA WHY MR. TORIYAMA'S AND MR. OTOMO'S ART WERE BOTH SO FASCINATING, BUT THERE WERE TWO THINGS THAT I WAS SURE OF. BOTH OF THEM DID WORK THAT SEEMED ORIGINAL AND HAD A GREAT SENSE OF STYLE. I HAD THE FEELING THAT THEIR EFFECTS, DESIGN AND ATTENTION TO DETAIL WERE TOTALLY DIFFERENT FROM THOSE OF OTHER PEOPLE. IN OTHER WORDS, I STARTED THINKING THAT WHAT "FASCINATING ART" MEANT TO ME WAS "ORIGINAL ART," AND THAT COPYCAT ART, NO MATTER HOW TECHNICALLY SKILLFUL, WAS MEANINGLESS.

AFTER THAT, I TRIED TO MAKE SURE THAT EVERYTHING I DREW WAS TRULY ORIGINAL... BUT I ALWAYS ENDED UP LETTING OUTSIDE INFLUENCES CREEP IN, AND MY END PRODUCT WASN'T ORIGINAL AFTER ALL. STILL UNSATISFIED WITH MY RESULTS, I BEGAN STUDYING THE WORK OF MANY DIFFERENT MANGA ARTISTS, ONE BY ONE, WONDERING IF I COULD FIND ANY OTHERS WHOSE ART COULD RIVAL THAT OF THE TWO I ALREADY REVERED.

THAT'S WHEN I REALIZED THAT THE ARTISTS WHOSE WORK I FOUND INTERESTING WERE ALL INFLUENCED EITHER BY ONE OR BOTH OF THE ABOVE TWO, OR BY SOMEONE ELSE, AND THAT A TOTALLY ORIGINAL STYLE IS VERY RARE. IN ANY CASE, I THOUGHT MR. OTOMO HAD THE BEST STYLE OF THEM ALL, SO I STARTED IMITATING HIM. IN THE BEGINNING OF EIGHTH OR NINTH GRADE, I BOUGHT ALL THE *AKIRA*-RELATED MATERIALS I COULD FIND -- THE ART BOOK, MANGA AND MOVIE MANGA -- AND FURIOUSLY COPIED THEM. BUT I CONTINUED TO STRIVE FOR MY OWN STYLE AND WORKED HARD AT ALL DIFFERENT SORTS OF ORIGINAL ART AS WELL. (LATER, I WOULD ENCOUNTER TWO OTHER ARTISTS WHOM I CAME TO CONSIDER ORIGINAL AND STYLISH, BUT THAT IS A TALE FOR ANOTHER DAY.)

 Number 90:

# What About My Training?!









BUT... WHY HIM?!

THIS STINKS...

PAT PAT / RIGHT?!

I SHALL NEVER FORGET THAT HUMILIATION...

HA HA... WELL, MAYBE OPPOSITES ATTRACT, OR...



...WOW, I DIDN'T KNOW YOU TWO KNEW EACH OTHER...



...YOU'RE THE WEAKEST AT THE BASICS.

AND, WELL... NARUTO, AMONG THE THREE GENIN IN CELL SEVEN...

THIS TIME, LISTEN CLOSELY AND LEARN IT RIGHT.



GRR!!

HEY! BOTH OF YOU... PLEASE...

INDEED! IF IT WEREN'T FOR KAKASHI'S REQUEST...

...I WOULD NEVER CHOOSE TO TEACH YOU!



HE'S A BETTER TEACHER THAN ME, I PROMISE!

NARUTO! MASTER EBISU IS AN EXCLUSIVE PRIVATE TUTOR WHO TEACHES THE ELITE... HE'S A SPECIAL JONIN!



...HOW IN THE WORLD DO I COME UP SHORT?!

WHOA THERE! COMPARED TO SAKURA AND SASUKE...



...PRIOR TO USE OF A TECHNIQUE.

THIS DIAGRAM REPRESENTS THE HEALTHY STATE OF FULL STAMINA.

...WHICH MOVE WITHIN THE BODY WHENEVER A NINJA USES NINJUTSU, TAIJUTSU OR GENJUTSU.

THESE SHOW, IN EASY TERMS, THE FLOW OF PHYSICAL AND MENTAL ENERGIES -- COLLECTIVELY CALLED "STAMINA"...

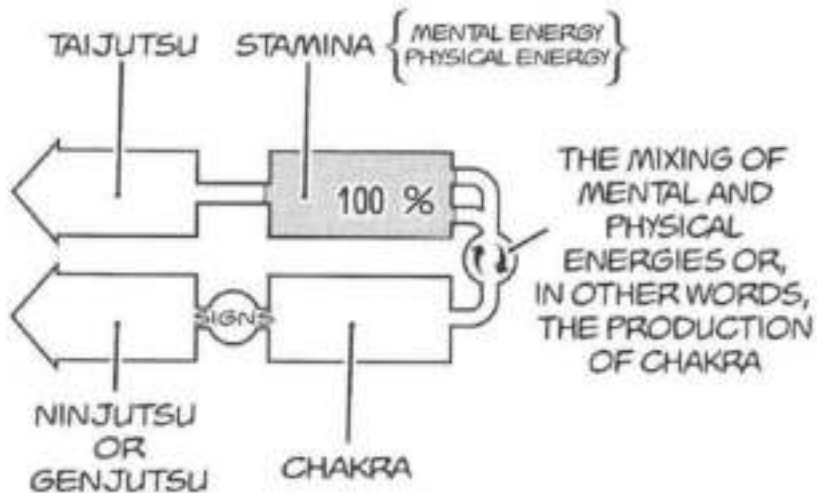

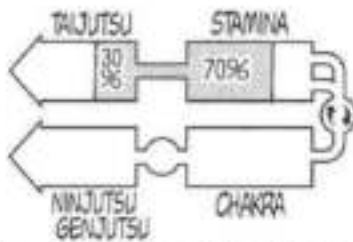

LEE USES 30% OF HIS STAMINA FOR THE TAIJUTSU. HIS REMAINING STAMINA IS 70%.

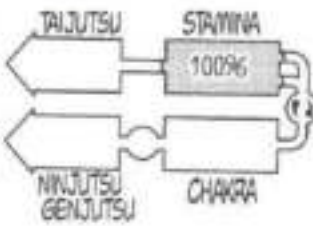

STAMINA CONTROL IS SIMPLE.

FIRST, IN THE CASE WHERE A NINJA IS GOING TO USE TAIJUTSU...

IT IS ONLY NECESSARY TO EXPEND THE PRECISE AMOUNT OF STAMINA REQUIRED BY THAT PARTICULAR MOVE.

TAIJUTSU DO NOT REQUIRE SIGNS AT ALL, NOR, WITH A FEW EXCEPTIONS, DO THEY REQUIRE CHAKRA.

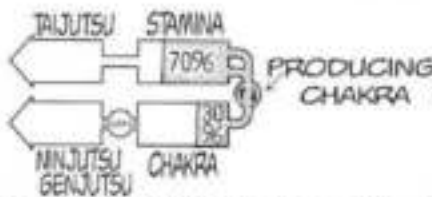

NARUTO HAS CONTRIBUTED 30% OF HIS STAMINA TO THE CREATION OF CHAKRA. 70% OF HIS STAMINA REMAINS.

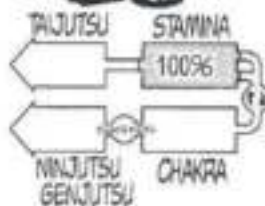

HOWEVER, IN THE CASE OF NINJUTSU OR GENJUTSU...

...ONE MUST FIRST AMASS THE AMOUNT OF CHAKRA REQUIRED TO PERFORM THE PARTICULAR TECHNIQUE!

SO IF YOUR STAMINA AND CHAKRA BOTH FELL TO 0%, YOU WOULD DIE!

OF COURSE, THE ENERGIES USED IN TAIJUTSU, NINJUTSU OR GENJUTSU ARE EXPENDED... AND THIS ARE LOST!

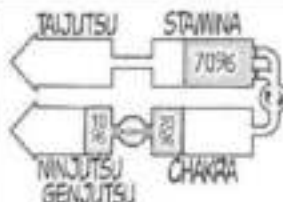
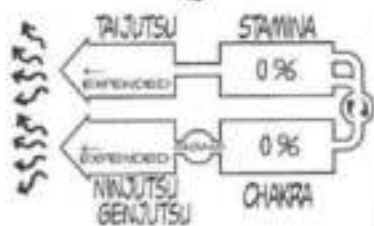

30% OF THE STAMINA WAS USED TO PRODUCE CHAKRA. ART OF THE DOPPELSÄNGER REQUIRES 10%.

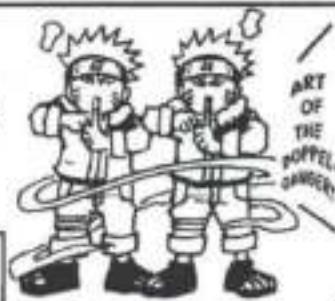

NEXT, ONE MUST USE COMPLEX SIGNS...

...TO CONTROL AND MANIPULATE THE CHAKRA BASED ON THE INDIVIDUAL TECHNIQUE!

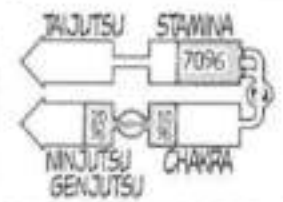

THE ART OF TRANSFORMATION USES 20%.



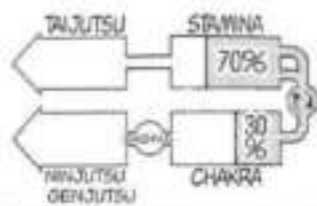

[SHE CONVERTS EXACTLY 30%]

EASY!



FIRST, IN SAKURA'S CASE, WHEN SHE INITIATES THIS TECHNIQUE, SHE IS ABLE TO CONVERT PRECISELY 30% OF HER STAMINA INTO CHAKRA.

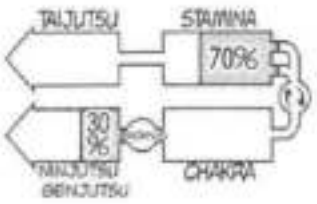

[SHE USES EXACTLY 30%]



ART OF THE DOPPELGANGER!

THEN, BECAUSE SHE CAN EXPERTLY CONTROL HER CHAKRA VOLUME AS WELL, WHEN SHE BEGINS MAKING HAND SIGNS...

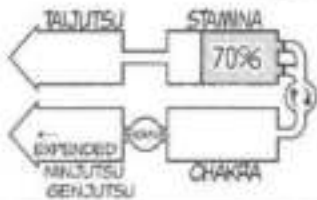

THREE DOPPELGANGERS!



...SHE CAN CLEANLY PRODUCE THREE COPIES OF HERSELF... AND STILL HAVE 70% OF HER STAMINA LEFT FOR LATER USE!

NOW... BUILDING UPON THAT, LET ME BREAK DOWN THE ART OF THE DOPPELGANGER FURTHER.

LET'S SAY 30% OF YOUR CHAKRA IS NEEDED TO CREATE THREE DOPPELGANGERS.



YEP! OKAY!



HE KEEPS DRONING ON AND ON... AND I DON'T UNDERSTAND A BIT OF IT...



NEXT... IN SASUKE'S CASE...

AND HE CAN ALSO CREATE THREE OF HIMSELF, BUT... SINCE SASUKE CANNOT USE OR RECYCLE THE SURPLUS CHAKRA BACK INTO HIS STAMINA POOL, THAT EXTRA 10% GOES TO WASTE... AND HE ONLY HAS 60% OF HIS STAMINA LEFT IN RESERVE!

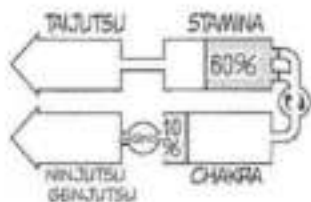

[THE REMAINING STAMINA IS AT 60%... AND THE EXTRA CHAKRA IS WASTED]

HOWEVER, HIS CHAKRA CONTROL THROUGH THE USE OF SIGNS IS JUST AS SKILLED AS SAKURA'S, SO... NO PROBLEMS THERE...

ART OF THE DOPPELGANGER!

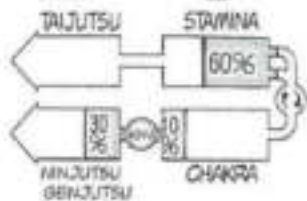

[HERE, HE'S JUST AS GOOD AS SAKURA]

HE'S NOT AS EFFICIENT AT CREATING CHAKRA, SO ALTHOUGH HE ONLY NEEDS 30%, HE PRODUCES 40%, OR 10% MORE THAN REQUIRED.

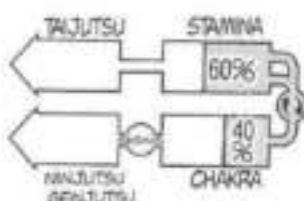

[HE PRODUCED 10% MORE THAN NECESSARY]



SO YOU END UP WITH ONLY 50% LEFT IN RESERVE, WASTE 40% AND BARELY CREATE A SINGLE DOPPELGANGER! THIS IS HOW DIFFERENT THE THREE OF YOU ARE JUST COMPARING THE SAME TECHNIQUE!

[STAMINA REMAINING = 50%  
WASTED CHAKRA = 40%]

AND FURTHERMORE, YOUR CHAKRA CONTROL FOR INITIATING TECHNIQUES THROUGH SIGNS IS SO POOR THAT YOU CAN ONLY USE 10% INSTEAD OF THE NECESSARY 30%...

ART OF THE DOPPELGANGER!

[ 30% IS THE FUNDAMENTALLY REQUIRED AMOUNT ]

YOU ARE EVEN WORSE THAN SASUKE AT MANIPULATING CHAKRA, SO YOU END UP PRODUCING 50% INSTEAD OF THE REQUIRED 30%.

[ PRODUCES 20% MORE THAN NECESSARY ]





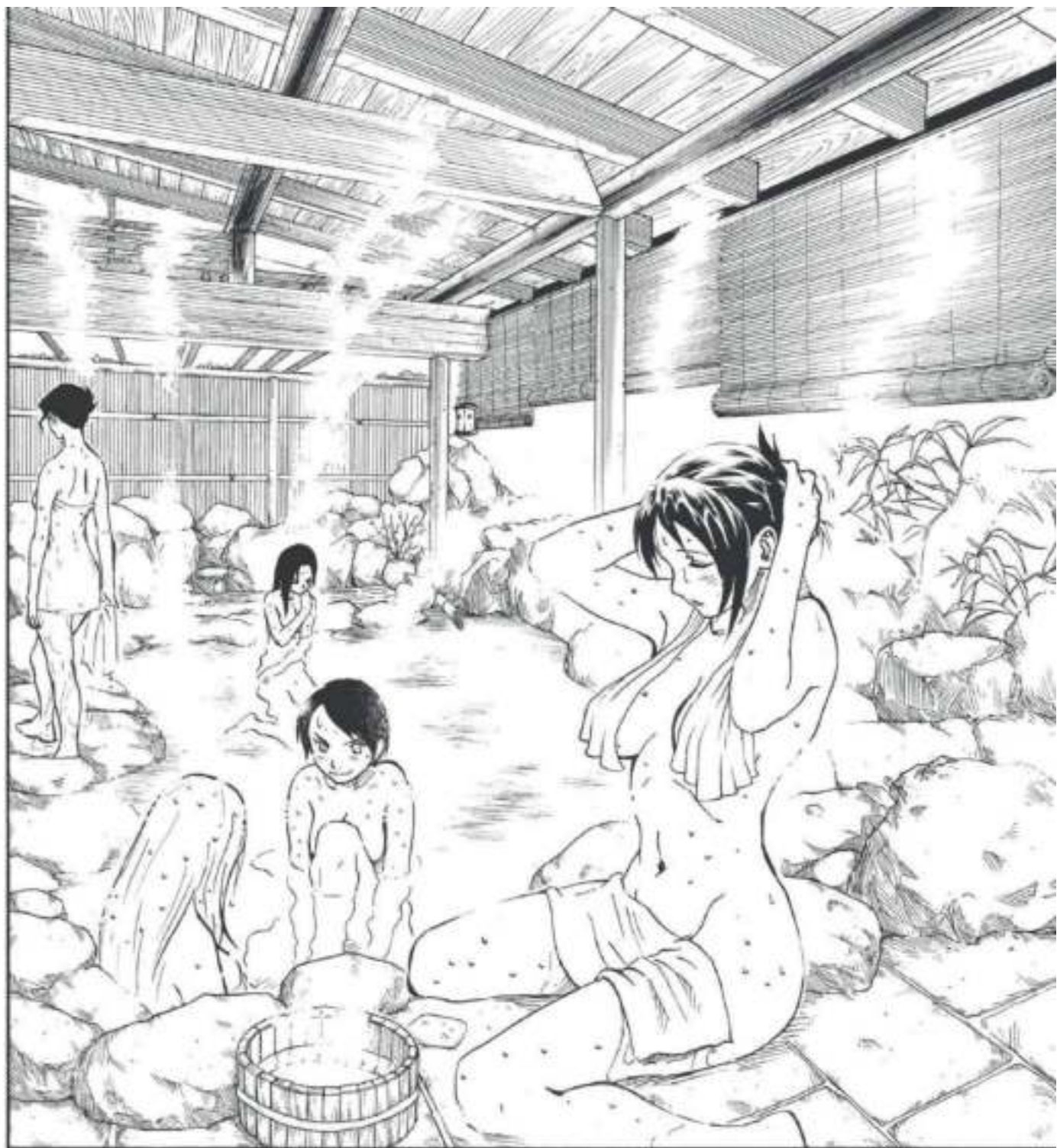





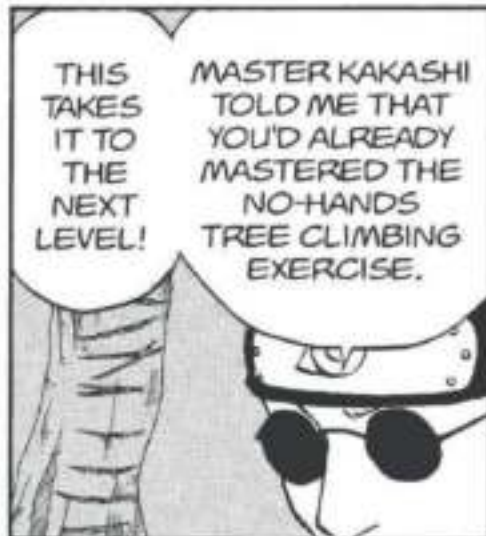







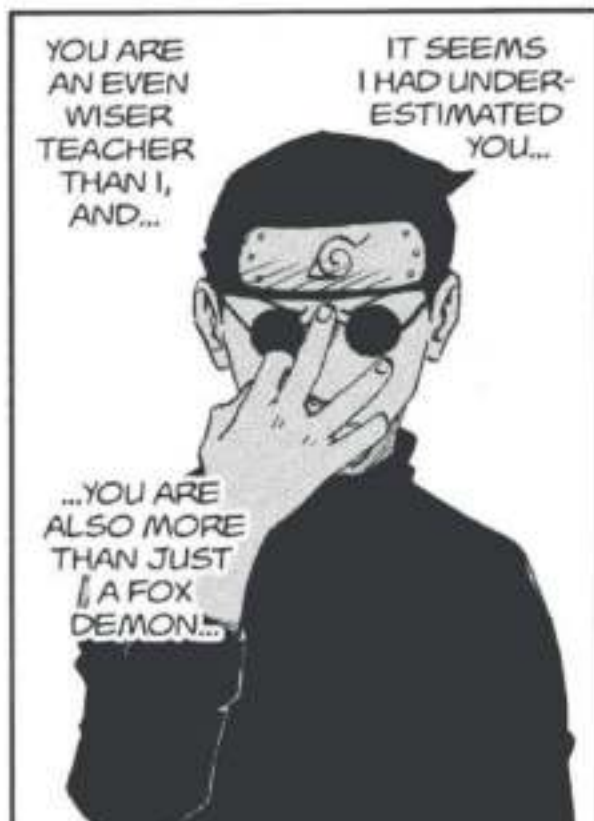

READ THIS WAY







YOU'LL GET US BUSTED... AND WHAT'LL WE DO THEN?!

DON'T MAKE A FUSS, EH...? SHEESH.

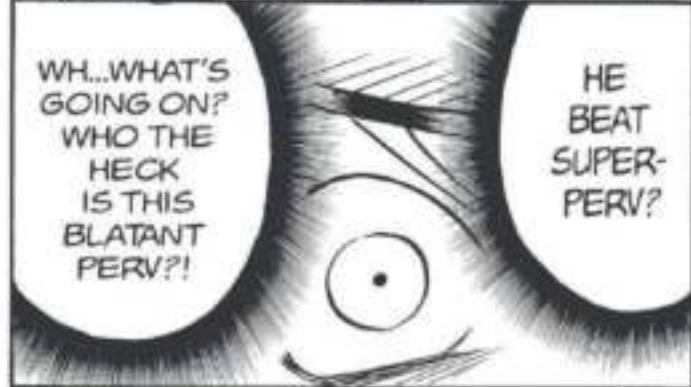



**vizMANGA**

For more information, visit [vizmanga.com](http://vizmanga.com)